



Model EX637A06

Intrinsically-safe, cryogenic, industrial, quartz shear ICP accel, 25mV/g, 4 to 1.5kHz, top exit, 2-pin conn.

Installation and Operating Manual

**For assistance with the operation of this product,
contact the PCB Piezotronics, Inc.**

**Toll-free: 800-959-4464
24-hour SensorLine: 716-684-0001
Fax: 716-684-3823
E-mail: imi@pcb.com
Web: www.imi-sensors.com**



Repair and Maintenance

PCB guarantees Total Customer Satisfaction through its “Lifetime Warranty Plus” on all Platinum Stock Products sold by PCB and through its limited warranties on all other PCB Stock, Standard and Special products. Due to the sophisticated nature of our sensors and associated instrumentation, **field servicing and repair is not recommended and, if attempted, will void the factory warranty.**

Beyond routine calibration and battery replacements where applicable, our products require no user maintenance. Clean electrical connectors, housings, and mounting surfaces with solutions and techniques that will not harm the material of construction. Observe caution when using liquids near devices that are not hermetically sealed. Such devices should only be wiped with a dampened cloth—never saturated or submerged.

In the event that equipment becomes damaged or ceases to operate, our Application Engineers are here to support your troubleshooting efforts 24 hours a day, 7 days a week. Call or email with model and serial number as well as a brief description of the problem.

Calibration

Routine calibration of sensors and associated instrumentation is necessary to maintain measurement accuracy. We recommend calibrating on an annual basis, after exposure to any extreme environmental influence, or prior to any critical test.

PCB Piezotronics is an ISO-9001 certified company whose calibration services are accredited by A2LA to ISO/IEC 17025, with full traceability to SI through N.I.S.T. In addition to our standard calibration services, we also offer specialized tests, including: sensitivity at elevated or cryogenic temperatures, phase response, extended high or low frequency response, extended range, leak testing, hydrostatic pressure testing, and others. For more information, contact your local PCB Piezotronics distributor, sales representative, or factory customer service representative.

Returning Equipment

If factory repair is required, our representatives will provide you with a Return Material Authorization (RMA) number, which we use to reference any information you have already provided and expedite the repair process. This number should be clearly marked on the outside of all returned package(s) and on any packing list(s) accompanying the shipment.

Contact Information

PCB Piezotronics, Inc.
3425 Walden Ave.
Depew, NY14043 USA
Toll-free: (800) 828-8840
24-hour SensorLine: (716) 684-0001
General inquiries: info@pcb.com
Repair inquiries: rma@pcb.com

For a complete list of distributors, global offices and sales representatives, visit our website, www.pcb.com.

Safety Considerations

This product is intended for use by qualified personnel who recognize shock hazards and are familiar with the precautions required to avoid injury. While our equipment is designed with user safety in mind, the protection provided by the equipment may be impaired if equipment is used in a manner not specified by this manual.

Discontinue use and contact our 24-Hour Sensorline if:

- Assistance is needed to safely operate equipment
- Damage is visible or suspected
- Equipment fails or malfunctions

For complete equipment ratings, refer to the enclosed specification sheet for your product.

Definition of Terms and Symbols

The following symbols may be used in this manual:



DANGER

Indicates an immediate hazardous situation, which, if not avoided, may result in death or serious injury.

**CAUTION**

Refers to hazards that could damage the instrument.

**NOTE**

Indicates tips, recommendations and important information. The notes simplify processes and contain additional information on particular operating steps.

The following symbols may be found on the equipment described in this manual:



This symbol on the unit indicates that high voltage may be present. Use standard safety precautions to avoid personal contact with this voltage.



This symbol on the unit indicates that the user should refer to the operating instructions located in the manual.



This symbol indicates safety, earth ground.



PCB工业监视和测量设备 - 中国RoHS2公布表

PCB Industrial Monitoring and Measuring Equipment - China RoHS 2 Disclosure Table

部件名称	有害物质					
	铅 (Pb)	汞 (Hg)	镉 (Cd)	六价铬 (Cr(VI))	多溴联苯 (PBB)	多溴二苯醚 (PBDE)
住房	0	0	0	0	0	0
PCB板	X	0	0	0	0	0
电气连接器	0	0	0	0	0	0
压电晶体	X	0	0	0	0	0
环氧	0	0	0	0	0	0
铁氟龙	0	0	0	0	0	0
电子	0	0	0	0	0	0
厚膜基板	0	0	X	0	0	0
电线	0	0	0	0	0	0
电缆	X	0	0	0	0	0
塑料	0	0	0	0	0	0
焊接	X	0	0	0	0	0
铜合金/黄铜	X	0	0	0	0	0
本表格依据 SJ/T 11364 的规定编制。						
0：表示该有害物质在该部件所有均质材料中的含量均在 GB/T 26572 规定的限量要求以下。						
X：表示该有害物质至少在该部件的某一均质材料中的含量超出 GB/T 26572 规定的限量要求。						
铅是欧洲RoHS指令2011/65/ EU附件三和附件四目前由于允许的豁免。						

CHINA RoHS COMPLIANCE

Component Name	Hazardous Substances					
	Lead (Pb)	Mercury (Hg)	Cadmium (Cd)	Chromium VI Compounds (Cr(VI))	Polybrominated Biphenyls (PBB)	Polybrominated Diphenyl Ethers (PBDE)
Housing	O	O	O	O	O	O
PCB Board	X	O	O	O	O	O
Electrical Connectors	O	O	O	O	O	O
Piezoelectric Crystals	X	O	O	O	O	O
Epoxy	O	O	O	O	O	O
Teflon	O	O	O	O	O	O
Electronics	O	O	O	O	O	O
Thick Film Substrate	O	O	X	O	O	O
Wires	O	O	O	O	O	O
Cables	X	O	O	O	O	O
Plastic	O	O	O	O	O	O
Solder	X	O	O	O	O	O
Copper Alloy/Brass	X	O	O	O	O	O

This table is prepared in accordance with the provisions of SJ/T 11364.

O: Indicates that said hazardous substance contained in all of the homogeneous materials for this part is below the limit requirement of GB/T 26572.

X: Indicates that said hazardous substance contained in at least one of the homogeneous materials for this part is above the limit requirement of GB/T 26572.

Lead is present due to allowed exemption in Annex III or Annex IV of the European RoHS Directive 2011/65/EU.

INSTRUCTIONS FOR USE – EX(M)637XYYYZ and EX(M)638XYYYZ Series

Model(s)	<p>EX(M)637XYYYZ and EX(M)638XYYYZ Series (M)-Represents an optional Metric Mounting Option X = is a letter that signifies family type. The letter will be from A to Z. YYY = is Two or Three numbers from 00 to 999 that signifies changes to filtering, gain, frequency response etc. Z= is an optional letter A to Z that signifies family type.</p>
Markings	<p>PCB Depew, NY IECEX ETL 19.0034X ITS19ATEX25015 ITS19ATEX45016 X Ex ia IIC T4 Ga, $-196^{\circ}\text{C} \leq T_{\text{amb}} \leq 121^{\circ}\text{C}$ Ex nA IIC T4 Gc, $-196^{\circ}\text{C} \leq T_{\text{amb}} \leq 121^{\circ}\text{C}$</p> <p>ETL c/us Intertek Listed 5010230 Class I, Div. 1, Groups A,B,C and D Class I, Div. 2, Groups A,B,C and D Class II, Div. 1, Groups E,F and G Class III Class I, Zone 0, AEx ia IIC T4 Ga, Class I, Zone 2, AEx nA IIC T4 Gc, $-196^{\circ}\text{C} \leq T_{\text{amb}} \leq 121^{\circ}\text{C}$</p> <p>Install per 70910</p>
Putting Into Service	<p>Powering: All ICP® sensors require constant current excitation for proper operation. For this reason, use only PCB constant-current signal conditioners or other approved constant-current sources. The power supply consists of a current-regulated, 2-20 mA at 18 to 28 VDC source. This power is regulated by a current-limiting circuit, which provides the constant-current excitation required for proper operation of ICP® sensors.</p> <p>In general, battery-powered devices offer versatility for portable, low-noise measurements, whereas line-powered units provide the capability for continuous monitoring. Consult the Vibration Division’s product catalog for more information about signal conditioners.</p> <p>NOTE: <i>Under no circumstances should a voltage be supplied to an ICP® accelerometer without a current-regulating diode or equivalent electrical circuit. This may include ohmmeters, multi-meters and continuity testers.</i></p>
Safe Use	<p>After completing the system setup, switch on the signal conditioner and allow 1 to 2 minutes for the system to stabilize. The meter (or LED) on the signal conditioner should be reading “green.” This indicates proper operation and you may begin taking measurements. If a faulty condition is indicated (red or yellow reading), first check all system connections, then check the functionality of the cable and signal conditioner. If the system still does not operate properly, consult a PCB factory representative.</p> <p>NOTE: <i>Always operate the accelerometer within the limitations listed on the enclosed Specification Sheet. Operating the device outside these parameters can cause temporary or permanent damage to the sensor.</i></p>

Assembling	The EX(M)637XYYYZ and EX(M)638XYYYZ Series have hermetically sealed stainless Steel housings, with a glass-sealed connector, and do not require any assembly. Only mounting to the machine being monitored using standard mounting accessories.
Dismantling	Other than removal from the mounting, there is no disassembly of the sensor required to take it out of service.
Maintenance	Routine maintenance, such as the cleaning of electrical connectors, housings, and mounting surfaces with solutions and techniques that will not harm the physical material of construction, is acceptable.
Servicing	Due to the sophisticated nature of the sensors and associated instrumentation provided by PCB Piezotronics, user servicing or repair is not recommended and, if attempted, may void the factory warranty. However, routine calibration of sensors and associated instrumentation is recommended as this helps build confidence in measurement accuracy and acquired data over time.
Repair	In the event that equipment becomes damaged or ceases to operate, arrangements should be made to return the equipment to PCB Piezotronics for repair. User servicing or repair is not recommended and, if attempted, may void the factory warranty.
Installation	Overview: Sensor must be mounted in order to be put into service. When choosing a mounting method, consider closely both the advantages and disadvantages of each technique. Characteristics like location, ruggedness, amplitude range, accessibility, temperature, and portability are extremely critical. However, the most important and often overlooked consideration is the effect the mounting technique has on the high-frequency performance of the accelerometer. Mounting methods include: Stud mount, adhesive mount, magnetic mount, or probe tip mount. Cabling: Care and attention to cable installation and cable condition is essential as the reliability and accuracy of any measurement system is no better than that of its weakest link. Due to the nature of vibration measurements, all sensor cables will ultimately fatigue and fail. Good installation practice will extend the life of a cable, however, it is highly recommended to keep spare cables on hand to enable continuation of the test in the event of a cable failure.
Adjustment	The sensor is a sealed device and no user adjustments are possible. However, routine calibration of sensors by the manufacturer is recommended as this helps build confidence in measurement accuracy and acquired data.
Danger Areas (for pressure-relief devices)	N/A – not a pressure relief device.
Training Instructions	Industrial sensors to be installed in Hazardous Locations must have this done by trained professionals according to EN/IEC 60079-14 requirements.
Details on Safety of Protection Category	Ex ia is “intrinsic safety”, which limits the energy of sparks and surface temperatures to safe levels. Ex nA is “Non-Sparking”, which ensures that there is no risk of arcing and sparking or hot surfaces during normal operation with a minimum IP protection of IP54.
Entity Parameters and Limits (Values)	Temperature Range: -196°C to +121°C Vmax = 28V, Imax = 93mA, Pi = 0.65W, Ci = 6.5nF, Li = 0µH
Special Conditions of Use	Version Ex nA: The apparatus must be only connect to an equipment whose electrical parameters are compatible with the electrical parameters. The apparatus shall be connected according to drawing 70910 (page 2/2). The connected cable and the connector must provide a minimum ingress protection of IP54, when assessed according to IEC 60079-0 and IEC 60079-15. Unused connector must be fitted with an appropriately rated blanking cover. Device complies with the requirements of the dielectric test per clause 6.3.13 of standard IEC 60079-11.
Essential Characteristics of tools fitted to the system (if any).	N/A – No tools are fitted to the system.
Drawings and Diagrams	70893,70898,70901

Other	ITS 19 ATEX 25015, ITS 19 ATEX 45016 X and ITS IECEx 19.0034X For ATEX protection “ia” – EN 60079-0 + A11:2013 and EN 60079-11:2012 For ATEX protection “nA” – EN 60079-0 + A11:2013 and EN 60079-15:2010
-------	---

For IECEx protection “ia” – IEC 60079-0 Ed. 6 and IEC 60079-11 Ed. 6 For IECEx protection “nA” – IEC 60079-0 Ed. 6 and IEC 60079-15 Ed. 4 ETL c/us Intertek Listed – 5010230
--

Note: Literature (such as the manual or marketing materials) describing the equipment or protective system must not contradict the instructions with regard to safety aspects.

Note: IMI Sensors is a Division of PCB Piezotronics. This Division is wholly contained in the PCB Piezotronics manufacturing facility at 3425 Walden Avenue, Depew, New York. Same address, same manufacturing facility. Some of the documentation contained in the Technical File associated with this application is labeled IMI Sensors, A PCB Piezotronics Div. and some is labeled simply PCB Piezotronics. PCB Piezotronics labeled drawing are higher-level drawings, which are used across multiple divisions, while IMI labeled drawing are specific to IMI models. There will be a mixture of IMI and PCB drawing to support this application, and in reality, they are the same entity however with an associated trade name (IMI) that is recognized by our customer base.

General OPERATING GUIDE

for use with

PIEZOELECTRIC ICP[®] ACCELEROMETERS

SPECIFICATION SHEET, INSTALLATION DRAWING AND CALIBRATION INFORMATION ENCLOSED

PCB ASSUMES NO RESPONSIBILITY FOR DAMAGE CAUSED TO THIS PRODUCT AS A RESULT OF PROCEDURES THAT ARE INCONSISTENT WITH THIS OPERATING GUIDE.

1.0 INTRODUCTION

Congratulations on the purchase of a quality, ICP[®] acceleration sensor. In order to ensure the highest level of performance for this product, it is imperative that you properly familiarize yourself with the correct mounting and installation techniques before attempting to operate this device. If, after reading this manual, you have any additional questions concerning this sensor or its application, feel free to call a factory Application Engineer at 716-684-0001 or your nearest PCB sales representative.

2.0 ICP[®] ACCELEROMETERS

Powered by simple, inexpensive, constant-current signal conditioners, these sensors are easy to operate and interface with signal analysis, data acquisition and recording instruments. The following features further characterize ICP[®] sensors:

- Fixed voltage sensitivity, regardless of cable type or length.
- Low-impedance output signal, which can be transmitted over long cables in harsh environments with virtually no loss in signal quality.
- Two-wire operation with low cost coaxial cable, two-conductor ribbon wire or twisted-pair cabling.
- Low-noise, voltage-output signal compatible with standard readout, signal analysis, recording, and data acquisition equipment.
- Low cost per-channel - ICP[®] accelerometers require only an inexpensive, constant-current signal conditioner to operate.

- Intrinsic self-test feature – monitoring the sensor's output bias voltage provides an indication of proper operation, faulty condition, and bad cables.

In the rear of this manual you will find a **Specification Sheet**, which provides the complete performance characteristics of your particular sensor.

3.0 OPTIONAL FEATURES

Many sensors are supplied with standard, optional features. When listed before the model number, the following prefix letters indicate that the sensor is manufactured or supplied with a particular optional feature: "A" option: adhesive mount; "HT" option: extended high temperature range; "J" option: electrically ground isolated; "M" option: metric mounting thread; "Q" option: extended discharge time constant; "T" option: built-in transducer electronic data sheet (TEDS); and "W" option: attached, water-resistant cabling. Other prefix letters, such as "K", "KR", "GK", "GKR", "KL", and "GKL", indicate that the sensor is ordered in kit form, including interconnect cabling and signal conditioner. If you have any questions or concerns regarding optional features, consult the Vibration Division's product catalog or contact a PCB factory representative.

4.0 INSTALLATION OVERVIEW

When choosing a mounting method, consider closely both the advantages and disadvantages of each technique. Characteristics like location, ruggedness, amplitude range, accessibility, temperature, and portability are extremely critical. However, the most important and often overlooked consideration is the effect the mounting technique has on the high-frequency performance of the accelerometer.

[®] ICP is a registered trademark of PCB Group, Inc., which uniquely identifies PCB sensors that incorporate built-in microelectronics.

Shown in figure 1 are six possible mounting techniques and their effects on the performance of a typical piezoelectric accelerometer. (Note that not all of the mounting methods may apply to your particular sensor). The mounting configurations and corresponding graph demonstrate how the high-frequency response of the accelerometer may be compromised as mass is added to the system and/or the mounting stiffness is reduced.

NOTE: *The low-frequency response is unaffected by the mounting technique. This roll-off behavior is typically fixed by the sensor's built-in electronics. However, when operating AC-coupled signal conditioners with readout devices having an input impedance of less than one megohm, the low frequency range may be affected. If necessary, contact a factory representative for further assistance.*

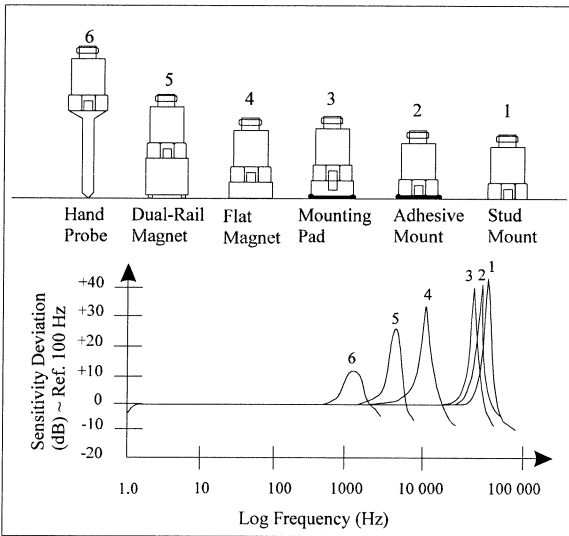

Figure 1. Assorted Mounting Configurations and Their Effects on High Frequency

4.1 STUD MOUNT

This mounting technique requires smooth, flat contact surfaces for proper operation and is recommended for permanent and/or secure installations. Stud mounting is also recommended when testing at high frequencies.

NOTE: *Do NOT attempt mounting on curved, rough, or uneven surfaces, as the potential for misalignment and limited contact surface may significantly reduce the sensor's upper operating frequency range.*

STEP 1: First, prepare a smooth, flat mounting surface, then drill and tap a mounting hole in the center of this area as shown in Figure 2 and in accordance with the enclosed **Installation Drawing**.

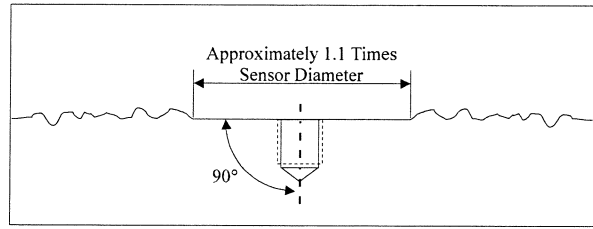

Figure 2. Mounting Surface Preparation

A precision-machined mounting surface with a minimum finish of 63 μin (0.00016 mm) is recommended. (If it is not possible to properly prepare the test structure mounting surface, consider adhesive mounting as a possible alternative). Inspect the area, checking that there are no burrs or other foreign particles interfering with the contact surface.

STEP 2: Wipe clean the mounting surface and spread on a light film of grease, oil, or similar coupling fluid prior to installation.

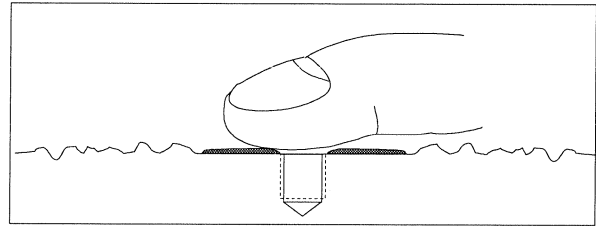

Figure 3. Mounting Surface Lubrication

Adding a coupling fluid improves vibration transmissibility by filling small voids in the mounting surface and increasing the mounting stiffness. For semi-permanent mounting, substitute epoxy or another type of adhesive.

STEP 3: Screw the mounting stud into the base of accelerometer and hand-tighten (this step is unnecessary for units having an integral mounting stud). Then, screw the sensor into the tapped hole that was prepared in the test object. Tighten the unit in place by applying, with a torque wrench, the recommended mounting torque, as listed on the enclosed **Installation Drawing**.

NOTE: *It is important to use a torque wrench during this step. Under-torquing the sensor may not adequately couple the device; over-torquing may result in stud failure.*

4.2 ADHESIVE MOUNT

Adhesive mounting is often used for temporary installation or when the test object surface cannot be adequately prepared for stud mounting. Adhesives like hot glue and wax perform well for temporary installations whereas two-part epoxies and quick-bonding gels (super glue) provide a more permanent installation. Two

techniques are used for adhesive mounting; they are via an adhesive mounting base (method 1 below) or direct adhesive mounting (method 2 below).

NOTE: *Adhesively mounted sensors often exhibit a reduction in high-frequency range. Generally, smooth surfaces and stiff adhesives provide the best high frequency response.*

METHOD 1 - Adhesive Mounting Base

This method involves attaching a base to the test structure, then securing the sensor to the base. This allows for easy removal of the accelerometer. Also, since many bases are manufactured of “hard-coated” aluminum, they provide electrical isolation to eliminate ground loops and reduce electrical interference that may propagate from the surface of the test object.

STEP 1: Prepare a smooth, flat mounting surface. A minimum surface finish of 63 μm (0.00016 mm) generally works best.

STEP 2: Stud-mount the sensor to the flat side of the appropriate adhesive mounting base according to the guidelines set forth in **STEPS 2** and **3** of the Stud Mount Procedure presented above.

STEP 3: Place a small portion of adhesive on the underside of the mounting base (the underside is discernable by the concentric grooves which are designed to accept the adhesive). Firmly press down on the assembly to displace any extra adhesive remaining under the base.

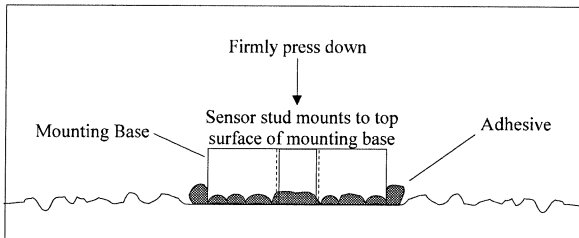

Figure 4. Mounting Base: Adhesive Installation

METHOD 2 - Direct Adhesive Mount

For restrictions of space or for convenience, most sensors can be adhesive-mounted directly to the test structure (an exception being units having integral mounting studs).

STEP 1: Prepare a smooth, flat mounting surface. A minimum surface finish of 63 μm (0.00016 mm) generally works best.

STEP 2: Place a small portion of adhesive on the underside of the sensor. Firmly press down on the top of the assembly to displace any adhesive. Be aware that

excessive amounts of adhesive can make sensor removal difficult. Also, adhesive that may invade the tapped mounting hole in the base of the sensor will compromise future ability to stud mount the unit.

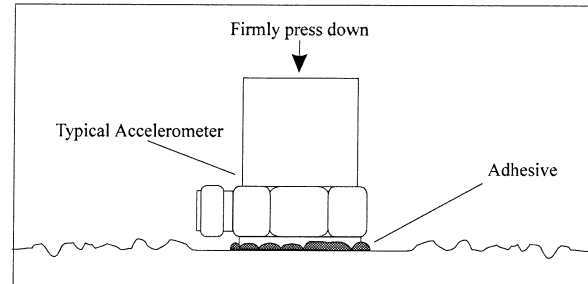

Figure 5. Direct Adhesive Mounting

4.2-1 ADHESIVE MOUNT REMOVAL (other than wax)

NOTE: *A debonder should always be used to avoid sensor damage.*

To avoid damaging the accelerometer, a debonding agent must be applied to the adhesive prior to sensor removal. With so many adhesives in use (everything from super glues, dental cement, epoxies, etc), there is no universal debonding agent available. The debonder for the Loctite 454 adhesive that PCB offers is Acetone. If you are using anything other than Loctite 454, you will have to check with the individual manufacturers for their debonding recommendations. The debonding agent must be allowed to penetrate the surface in order to properly react with the adhesive, so it is advisable to wait a few minutes before removing the sensor.

After the debonding agent has set, you can use an ordinary open-end wrench if the accelerometer has a hex base or square base, or the supplied removal tool for teardrop accelerometers. After attaching either, use a gentle shearing (or twisting) motion (by hand only) to remove the sensor from the test structure.

4.3 MAGNETIC MOUNT

Magnetic mounting provides a convenient means for making quick, portable measurements and is commonly used for machinery condition monitoring, predictive maintenance, spot checks, and vibration trending applications.

NOTE: *The correct magnet choice and an adequately prepared mounting surface are critical for obtaining reliable measurements, especially at high frequencies. Poor installations can cause as much as a 50% drop in the sensor frequency range.*

Not every magnet is suitable for all applications. For example, rare earth magnets are commonly used because

of their high strength. Flat magnets work well on smooth, flat surfaces, while dual-rail magnets are required for curved surfaces such as motor housings and pipes. In the case of non-magnetic or rough surfaces, it is recommended that the user first weld, epoxy, or otherwise adhere a steel mounting pad to the test surface. This provides a smooth location for mounting and a target to insure that subsequent measurements for trending purposes are taken at the same location.

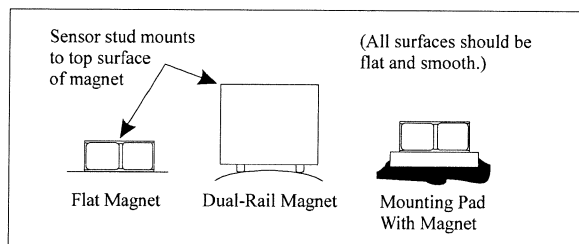

Figure 6. Magnet Types

STEP 1: Prepare a smooth, flat mounting surface. A minimum surface finish of 63 μin (0.00016 mm) generally works best. After cleaning the surface and checking for burrs, apply a light film of silicone grease, machine oil, or similar-type coupling fluid.

STEP 2: After choosing the correct magnet type, inspect the magnet, verifying that its mounting surfaces are flat and smooth.

STEP 3: Stud-mount the accelerometer to the appropriate magnet according to the guidelines set forth in **STEP 3** of the above Stud Mount Procedure.

STEP 4: To avoid damage to the sensor, install the magnet/sensor assembly to the prepared test surface by gently “rocking” or “sliding” it into place.

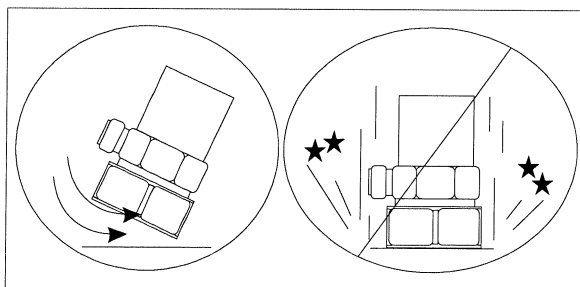

Figure 7. Magnet Mounting

CAUTION: Magnetically mounting of an accelerometer has the potential to generate very high (and very damaging) acceleration (g) levels. To prevent such damage, exercise caution and install the assembly gently by rocking it into place. If shock is expected to be a particular concern, use a sensor with built-in shock protection. For further assistance, contact a factory representative.

4.4 HANDHELD OR PROBE TIP MOUNT

This method is NOT recommended for most applications. Both the accuracy and repeatability at low (<5 Hz) and high frequency (>1 kHz) ranges are questionable. It is generally used only for machinery condition monitoring, when installation space is restricted, or other portable trending applications. The technique, however, can be useful for initially determining locations of greatest vibration to establish a permanent sensor installation point.

5.0 CABLING

Care and attention to cable installation and cable condition is essential as the reliability and accuracy of any measurement system is no better than that of its weakest link. Due to the nature of vibration measurements, all sensor cables will ultimately fatigue and fail. Good installation practice will extend the life of a cable, however, it is highly recommended to keep spare cables on hand to enable continuation of the test in the event of a cable failure.

STEP 1: Ascertain that you have the correct cable type.

One cable type cannot satisfy all applications. ICP® sensors can be operated with any ordinary two-wire or coaxial cable. Special, low-noise cables that are typically recommended for use with high-impedance, charge-output sensors can also be used. For applications requiring conformity to CE , low noise cables are essential. Industrial applications often require shielded, twisted-pair cables to reduce the effects of EMI and RFI that is present near electrical motors and machinery. Teflon-jacketed cabling may be necessary to withstand corrosive environments and higher temperatures. Consult the Vibration Division’s product catalog for more information about cables or feel free to contact a factory representative for a specific recommendation on cables that are best suited for your application.

STEP 2: Connect the cable to the accelerometer.

A small amount of thread-locking compound placed on the connector threads prior to attachment helps secure the cable during testing. In wet, oily, or dirty environments, the connection can be sealed with silicone rubber sealant, O-rings, and flexible, heat-shrink tubing.

Coaxial Cables: Make connection by inserting the cable’s connector pin into the sensor’s mating socket. Then thread the connector into place by turning the cable connector’s outer shell onto the accelerometer’s electrical connector.

NOTE: Do not spin the accelerometer while holding the cable connector stationary, as this will cause undue

friction on the center pin of the cable connector and lead to premature fatigue.

Multi-pin connectors: Make connection by inserting the sensor's mating pins onto the cable connector's mating sockets. Then thread the connector into place by turning the cable connector's outer shell onto the accelerometer's electrical connector.

Pigtail Connections: Certain miniature accelerometers and shock sensors are provided with lightweight cables attached to "Pigtail" connections. This type of connection reduces overall weight and incidence of connection intermittency under shock conditions. In the event of a cable or connection failure, the cables may be repaired in the field simply by re-soldering the stripped leads to the exposed pins on the sensor. (Check the **Installation Drawing** to determine signal and ground pins). In many cases, it is also helpful to protect the solder joint with heat-shrink tubing or epoxy.

NOTE: If you do not have the experience or resources to attach pigtail leads, consult PCB to discuss factory attachment. Damage to internal electronics may be caused by excessive heat during soldering and such failure is not covered by warranty.

STEP 3: Route the cable to the signal conditioner, making certain to relieve stress on the sensor/cable connection. Also, minimize cable motion by securing it with tape, clamps or ties at regular intervals.

Common sense should be used to avoid physical damage and minimize electrical noise. For instance, avoid routing cables near high-voltage wires. Do not route cables along floors or walkways where they may be stepped on or become contaminated. To avoid ground loops, shielded cables should have the shield grounded at one end only, typically at the signal conditioner.

STEP 4: Finally, connect the remaining cable end to the signal conditioner. It is good practice to dissipate any electrical charge that may have accumulated in the cable by shorting the signal pin to the ground pin or shell prior to attachment.

6.0 POWERING

All ICP[®] sensors require constant current excitation for proper operation. For this reason, use only PCB constant-current signal conditioners or other approved constant-current sources. A typical system schematic is shown in Figure 8.

NOTE: Damage to the built-in electronics resulting from the application of incorrect power, or the use of an unapproved power source, is NOT covered by warranty.

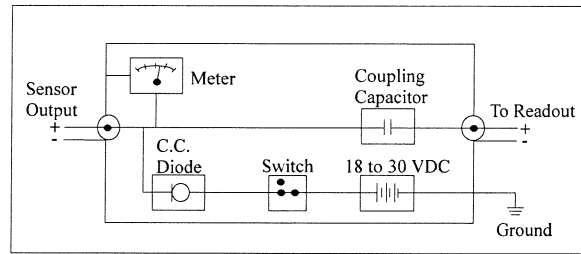

Figure 8. Typical System Schematic

The power supply consists of a current-regulated, 18 to 30 VDC source. This power is regulated by a current-limiting circuit, which provides the constant-current excitation required for proper operation of ICP[®] sensors.

In general, battery-powered devices offer versatility for portable, low-noise measurements, whereas line-powered units provide the capability for continuous monitoring. Consult the Vibration Division's product catalog for more information about signal conditioners.

NOTE: Under no circumstances should a voltage be supplied to an ICP[®] accelerometer without a current-regulating diode or equivalent electrical circuit. This may include ohmmeters, multi-meters and continuity testers.

Meters or LEDs are used on PCB signal conditioners to monitor the bias voltage on the sensor output signal, to check sensor operation, and detect cable faults. Normally, a "yellow" reading indicates an open circuit; "green" indicates normal operation; and "red" indicates either a short or overload condition. Finally, a capacitor at the output stage of the device removes the sensor output bias voltage from the measurement signal. This provides a zero-based, AC-coupled output signal that is compatible with most standard readout devices.

NOTE: Units having a low bias voltage may be in the "red," when actually they are working properly. If suspect, the bias voltage can be checked with a voltmeter attached to a "T" connector installed on the input connector to the signal conditioner.

Note: For readout devices having an input impedance near one gigohm (as encountered with some A to D converters), it may be necessary to place a one megohm resistor in parallel to the readout input to eliminate slow turn-on and signal drift.

Today, many FFT analyzers, data acquisition modules, and data collectors have the proper constant-current excitation built-in for direct use with ICP[®] sensors. Before using this feature, however, check that the supply voltage and constant current are within acceptable limits for use with your particular sensor. (Check enclosed **Specification Sheet**). Please contact the respective signal

conditioner manufacturer or check the product manual for more information.

7.0 OPERATING

After completing the system setup, switch on the signal conditioner and allow 1 to 2 minutes for the system to stabilize. The meter (or LED) on the signal conditioner should be reading “green.” This indicates proper operation and you may begin taking measurements. If a faulty condition is indicated (red or yellow reading), first check all system connections, then check the functionality of the cable and signal conditioner. If the system still does not operate properly, consult a PCB factory representative.

NOTE: Always operate the accelerometer within the limitations listed on the enclosed *Specification Sheet*. Operating the device outside these parameters can cause temporary or permanent damage to the sensor.

8.0 ACCELEROMETER CALIBRATION

Accelerometer calibration provides, with a definable degree of accuracy, the necessary link between the physical quantity being measured and the electrical signal generated by the sensor. In addition, other useful information concerning operational limits, physical parameters, electrical characteristics, or environmental influences may also be determined. Without this link, analyzing data becomes a nearly impossible task. Fortunately, most sensor manufacturers provide a calibration record that documents the exact characteristics of each sensor. (The type and amount of data varies depending on the manufacturer, sensor type, contractual regulations, and other special requirements).

Under normal conditions, piezoelectric sensors are extremely stable, and their calibrated performance characteristics do not change over time. However, the sensor may be temporarily or permanently affected by harsh environments influences or other unusual conditions that may cause the sensor to experience dynamic phenomena outside of its specified operating range. This change manifests itself in a variety of ways, including: a shift of the sensor resonance due to a cracked crystal; a temporary loss of low-frequency measuring capability due to a drop in insulation resistance; or total failure of the built-in microelectronic circuit due to a high mechanical shock.

For these reasons, it is recommended that a recalibration cycle be established for each accelerometer. This schedule is unique and is based on a variety of factors, such as: extent of use, environmental conditions, accuracy requirements, trend information obtained from previous calibration records, contractual regulations, frequency of “cross-checking” against other equipment, manufacturer recommendation, and any risk associated with incorrect

readings. International standards, such as ISO 10012-1, provide insight and suggest methods for determining recalibration intervals for most measuring equipment. With the above information in mind and under “normal” circumstances, PCB conservatively suggests a 12- to 24-month recalibration cycle for most piezoelectric accelerometers.

NOTE: It is good measurement practice to verify the performance of each accelerometer with a *Handheld Shaker* or other calibration device before and after each measurement. The *PCB Handheld Shaker* operates at a fixed frequency and known amplitude (1.0 g) to provide a quick check of sensor sensitivity.

8.1 RECALIBRATION SERVICE

PCB offers recalibration services for our piezoelectric accelerometers, as well as units produced by other manufacturers. Our internal metrology laboratory is certified to ISO 9001, accredited by A2LA to ANSI/IEC 17025 and ANSI/NCSL Z540-1, complies with ISO 10012-1 (and former MIL-STD-45662A), and uses equipment directly traceable to NIST. Our investment in equipment, traceability and conformance to industry standards ensures accurate calibration against relevant specifications, in a timely fashion.

8.2 BACK-TO-BACK CALIBRATION THEORY

Many companies choose to purchase the equipment necessary to perform the recalibration procedure in house. While this may result in both a savings of time and money, it has also been attributed to incorrect readings and costly errors. Therefore, in an effort to prevent the common mistakes associated with customer-performed calibration, this document includes a broad overview of the Back-to-Back Calibration technique. This technique provides a quick and easy method for determining the sensitivity of a test accelerometer over a wide frequency range.

Back-to-Back Calibration is perhaps the most common method for determining the sensitivity of piezoelectric accelerometers. This method relies on a simple comparison to a previously calibrated accelerometer, typically referred to as a reference standard.

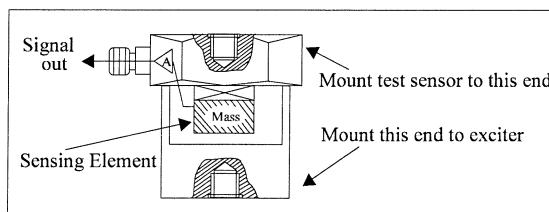

Figure 9. Reference Standard Accelerometer

These high-accuracy devices, which are directly traceable to a recognized standards laboratory, are designed for stability, as well as configured to accept a test accelerometer. By mounting a test accelerometer to the reference standard and then connecting this combination to a suitable vibration source, it is possible to vibrate both devices and compare the data as shown in Figure 10. (Test set-ups may be automated and vary, depending on the type and number of accelerometers being calibrated).

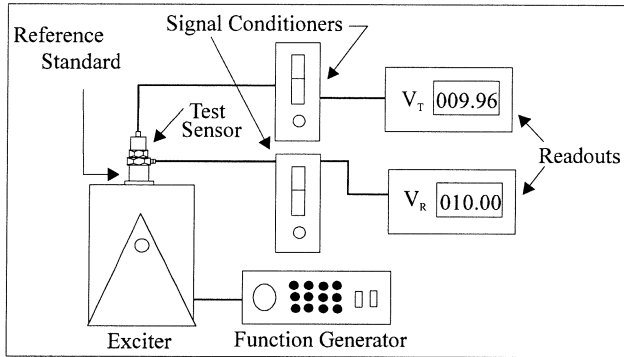

Figure 10. Typical Back-to-Back Calibration System

Because the acceleration is the same on both sensors, the ratio of their outputs (V_T/V_R) must also be the ratio of their sensitivities. With the sensitivity of the reference standard (S_R) known, the exact sensitivity of the test sensor (S_T) is easily calculated by using the following equation:

$$S_T = S_R (V_T/V_R)$$

By varying the frequency of the vibration, the sensor may be calibrated over its entire operating frequency range. The typical response of an unfiltered accelerometer is shown in Figure 11.

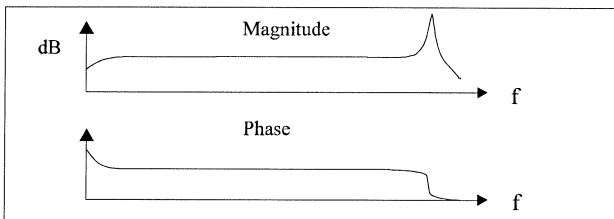

Figure 11. Typical Test Accelerometer Response

8.3 PCB CALIBRATION PROCEDURE

Numerous precautions are taken at PCB to insure accurate and repeatable results. This section provides a brief overview of the primary areas of concern.

Since the Back-to-Back Calibration technique relies on each sensor experiencing an identical acceleration level, proper mounting of the test sensor to the reference standard is imperative. Sensors with mounting holes are attached directly to the reference standard with a stud

tightened to the recommended mounting torque. A shouldered mounting stud is typically used to prevent the stud from “bottoming out” in the hole. Both mounting surfaces are precision-machined and lapped to provide a smooth, flat interface according to the manufacturer’s specification. A thin layer of silicone grease is placed between the mating surfaces to fill any imperfections and increase the mounting stiffness. The cables are stress-relieved by first routing them to the shaker head, then to a nearby stationary location. This reduces cable motion, which is especially important when testing charge output sensors, and helps to prevent extraneous motion or stresses from being imparted into the system. A typical set-up is shown in Figure 12.

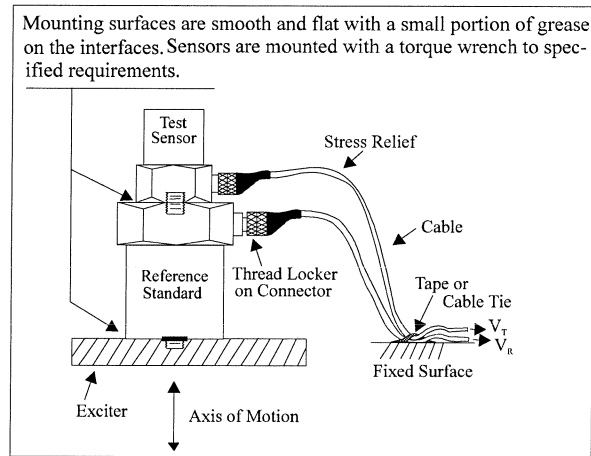

Figure 12. Typical Calibration Set-Up

Adhesively mounted sensors use similar practices. However, in this case, a small portion of quick-bonding gel, or similar temporary adhesive, is used to attach the test sensor to a reference standard designed with a smooth, flat mounting surface.

In addition to mounting, the selection of the proper equipment is critical. Some of the more important considerations include: 1) the reference standard must be specified and previously calibrated over the frequency and/or amplitude range of interest; 2) the shaker should be selected to provide minimal transverse (lateral) motion and minimal distortion; and 3) the quality of the meters, signal generator, and other devices should be selected so as to operate within the limits of permissible error.

8.4 COMMON MISTAKES

Most calibration errors are caused by simply overlooking some of the fundamental principals of dynamics. This section attempts to address some of the more common concerns.

For stud-mount sensors, always mount the accelerometer directly to the reference standard. Ensure that the mounting surfaces are smooth, flat, and free of any burrs. Always use a

coupling fluid, such as silicone grease, in the mounting interface to maintain a high mounting stiffness. Mount the sensor according to the manufacturer's recommended mounting torque. DO NOT use any intermediate mounting adaptors, as the mounted resonant frequency may be reduced, and thereby compromise the high-frequency performance. If necessary, use adaptor studs.

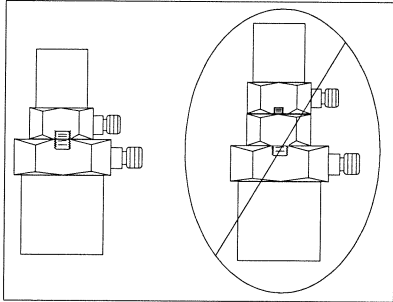

Figure 13. Stud Mounting

For adhesive mount sensors, use a thin, stiff layer of temporary adhesive such as quick-bonding gel or superglue. DO NOT use excessive amounts of glue or epoxy, as the mounting stiffness may be reduced and compromise high-frequency performance. It may also damage the sensor during removal.

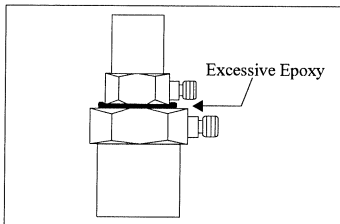

Figure 14. Incorrect Adhesive Mounting

Triaxial accelerometers should always be mounted directly to the reference standard. Unless absolutely required, DO NOT use adaptors to re-orient the sensor along the axis of motion, as the mounting stiffness may be altered. The vibration at the test sensor's sensing element may differ from the vibration at the reference standard due to a "cantilever" effect, seen in Figure 15.

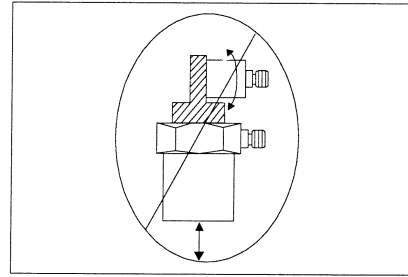

Figure 15. Mounting Triaxial Sensors (Incorrect)

Understand Back-to-Back Calibration limitations. Do not expect the uncertainty of calibration to be any better than $\pm 2\%$. (In fact, the uncertainty may be as high as $\pm 3\%$ or $\pm 4\%$ for frequencies < 10 Hz or > 2 kHz.) Since large sensors may affect high-frequency accuracy, verify that the test sensor does not mass load the reference standard. Validate your calibration system with another accelerometer prior to each calibration session. Check with the manufacturer for exact system specifications.

8.5 CONCLUSIONS

Without an adequate understanding of dynamics, determining what, when, and how to test a sensor is a difficult task. Therefore, each user must weigh the cost, time, and risk associated with self-calibration versus utilizing the services of an accredited laboratory.

9.0 SERVICE

See the supplement sheet, contained in this manual, for information on our warranty, service, repair, and return policies and instructions.

When unexpected measurement problems arise, call our 24-hour SensorLineSM to discuss your immediate dynamic instrumentation needs with a factory representative. Dial 716-684-0001.



3425 Walden Avenue, Depew, NY 14043-2495 USA **Vibration Division toll-free 888-684-0013**
24-hour SensorLineSM 716-684-0001 FAX 716-685-3886 E-mail vibration@pcb.com Website www.pcb.com

A PCB GROUP COMPANY

ISO 9001 CERTIFIED

A2LA ACCREDITED to ISO 17025

© 2002 PCB Group, Inc. In the interest of constant product improvement, specifications are subject to change without notice.

PCB and ICP are registered trademarks of PCB Group, Inc. SensorLine is a service mark of PCB Group, Inc.

All other trademarks are properties of their respective owners.

Manual Number: 18292
Manual Revision: B
ECN Number: 19829

VIB-ICPMANUAL-05

Printed in U.S

PCB Piezotronics Inc. claims proprietary rights in the information disclosed hereon. Neither it nor any reproduction thereof will be disclosed to others without the written consent of PCB Piezotronics Inc.

70910

SCHEDULE DRAWING

NO MODIFICATIONS PERMITTED WITHOUT REFERENCE TO THE NOTIFIED BODY

REVISIONS		
REV	DESCRIPTION	DIN
NR	RELEASED TO DRAFTING	49059

B

- 4 SHIELDS TO BE EARTHED AT BARRIER ENDS.
- 3 THE INSTALLER SHALL INSURE THAT THE TRANSDUCER MOUNTING STRUCTURE IS AT THE SAME GROUNDING POTENTIAL AS THE BARRIER GROUND. TOTAL EARTH LOOP IMPEDANCE SHALL BE LESS THAN 1 OHM.
- 2 BARRIER WILL BE MOUNTED IN AN ENCLOSURE THE SUITABILITY OF WHICH WILL BE DETERMINED BY LOCAL AUTHORITIES.

1 ENTITY APPLICATION

BARRIER		I.S. APPARATUS
Voc/Uo	≤	V _{MAX} / UI
Isc/Io	≤	I _{MAX} / II
Ca/Co	>	CI + C _{CABLE}
La/Lo	>	LI + L _{CABLE}
Po	≤	PI (CENELEC ONLY)

BARRIERS WITHIN THE SPECIFIED LIMITATIONS ARE PERMITTED

ENTITY PARAMETERS
EX(M)637XXXX AND EX(M)638XXXX SERIES:
U_i = 28V
I_i = 93mA
P_i = 0.65W
C_i = 6.5nF
L_i = 0H

CERTIFIED BY THE APPROPRIATE APPROVAL AUTHORITY FOR CONNECTION TO THE FOLLOWING AREAS:

- NORTH AMERICA:
ZONE 0
AEx ia IIC T4 Ga
- DIV 1
CLASS I, GROUPS A,B,C,D
CLASS II, GROUPS E,F,G
CLASS III
- EUROPE:
ZONE 0
Ex ia IIC T4 Ga

FOR MODELS EX637XXXX AND EX638XXXX SERIES, C_i IS SPECIFIED AT A MAXIMUM CABLE LENGTH OF 1000'. FOR SHORTER CABLE LENGTHS, C_i IS DECREASED BY 61pF/FT.

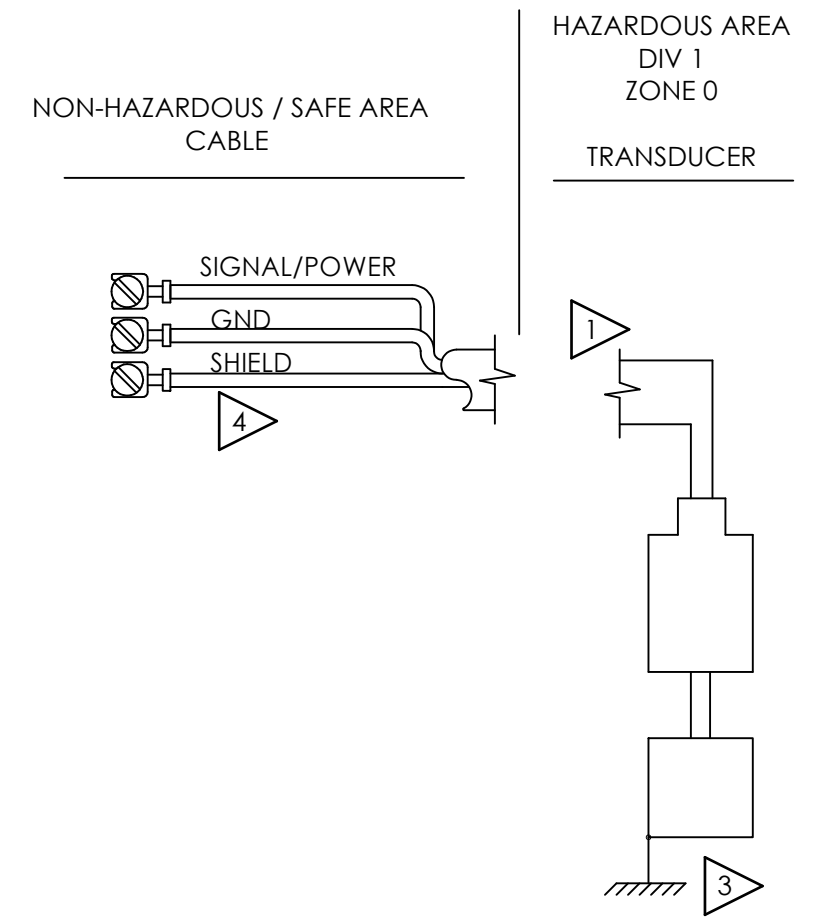
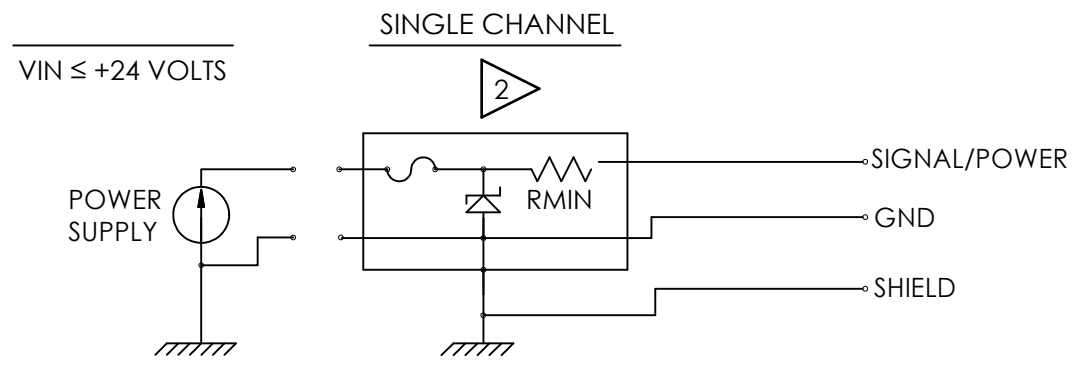

NO CHANGES WITHOUT APPROVAL

A

<small>UNLESS OTHERWISE SPECIFIED DIMENSIONS ARE IN INCHES DECIMALS X ± .05 XX ± .01 XXX ± .005 XXXX ± .0005 ANGLES ± 2 DEGREES FILLET AND RADII .003 - .005 HEX DIMENSIONS ARE: ≤ .5 + .000 / - .003 > .5 + .000 / - .005 INTERNAL THREAD DEPTH MIN. REMOVE ALL BURRS SHARP = R.000 - R.003</small>	DRAWN		CHECKED		ENGINEER		 3425 WALDEN AVE. DEPEW, NY 14043 (716) 684-0002 E-MAIL: sales@pcb.com CODE IDENT. NO. 52681 SCALE: NONE SHEET 1 OF 2
	KSR	11/4/19	KSR	11/4/19	GGG	11/4/19	
	TITLE APPROVAL INTERCONNECTION DIV 1, ZONE 0						
	DWG. NO. 70910						

4

3

2

1

B

A

70910

PCB Piezotronics Inc. claims proprietary rights in the information disclosed hereon. Neither it nor any reproduction thereof will be disclosed to others without the written consent of PCB Piezotronics Inc.

SCHEDULE DRAWING

NO MODIFICATIONS PERMITTED WITHOUT REFERENCE TO THE NOTIFIED BODY

REVISIONS

REV	DESCRIPTION	DIN
	-SEE SHEET 1-	

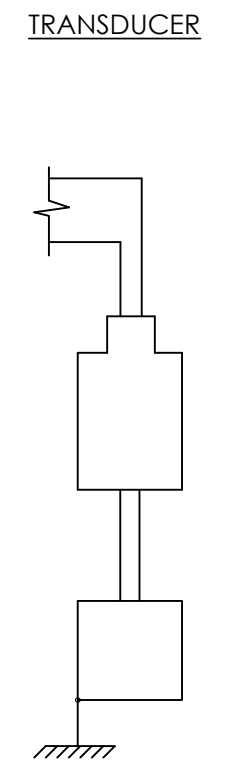
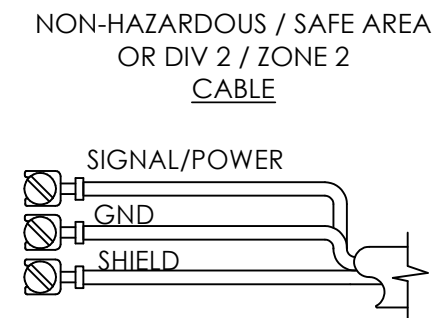
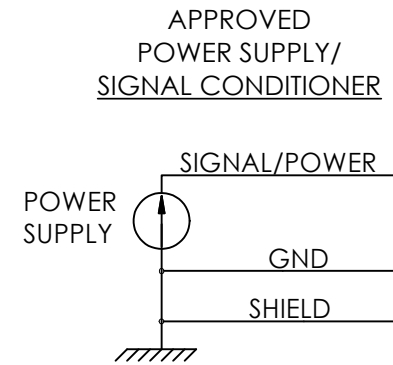

NO CHANGES WITHOUT APPROVAL

- 7.) ⚠ NE PAS DÉBRANCHER LORSQU'UN EMPLACEMENT DANGEREUX EST PRÉSENT
- 6.) ⚠ DO NOT DISCONNECT WHEN HAZARDOUS LOCATION IS PRESENT
- 5.) ⚠ NE PAS DÉBRANCHER LORSQUE ÉNERGÉ
- 4.) ⚠ DO NOT DISCONNECT WHEN ENERGIZED
- 3.) EQUIPMENT CONSISTS OF TRANSIENT PROTECTION DEVICE TO BE SET AT A LEVEL NOT EXCEEDING 140% OF RATED POWER SUPPLY VOLTAGE (30V)
- 2.) FOR GUIDANCE ON CANADIAN INSTALLATION, REFER TO CEC PART I. FOR GUIDANCE ON U.S. INSTALLATION, INSTALL IN ACCORDANCE WITH NEC [ANSI/NFPA70] AND [ANSI/ISA RP12.6]

1.) CERTIFIED BY THE APPROPRIATE APPROVAL AUTHORITY FOR CONNECTION TO THE FOLLOWING AREAS:

NORTH AMERICA:

ZONE 2
AEx nA IIC T4 Gc

DIV 2
CLASS I, GROUPS A,B,C,D

EUROPE:

ZONE 2
Ex nA IIC T4 Gc

UNLESS OTHERWISE SPECIFIED DIMENSIONS ARE IN INCHES DECIMALS X ± .05 XX ± .01 XXX ± .005 XXXX ± .0005 ANGLES ± 2 DEGREES FILLETS AND RADII .003 - .005
HEX DIMENSIONS ARE: ≤ .5 + .000 / - .003 > .5 + .000 / - .005
INTERNAL THREAD DEPTH MIN. REMOVE ALL BURRS SHARP = R.000 - R.003

DRAWN		CHECKED		ENGINEER	
KSR	11/4/19	KSR	11/4/19	GGG	11/4/19

TITLE
**APPROVAL
INTERCONNECTION
DIV 2, ZONE 2**



3425 WALDEN AVE. DEPEW, NY 14043
(716) 684-0002 E-MAIL: sales@pcb.com

CODE IDENT. NO. 52681
DWG. NO. 70910

SCALE: NONE SHEET 2 OF 2

Model Number
637A06

INDUSTRIAL ICP® ACCELEROMETER

Revision: B
ECN #: 53514

Performance	ENGLISH	SI	
Sensitivity(± 10 %)	25 mV/g	2.54 mV/(m/s ²)	[1]
Measurement Range	± 200 g	± 1,962 m/s ²	
Frequency Range(± 5 %)	600 to 24,000 cpm	10 to 400 Hz	[2]
Frequency Range(± 3 dB)	240 to 90,000 cpm	4 to 1,500 Hz	
Filter Type	Low Pass	Low Pass	
Electrical Filter Corner Frequency	1.5 kHz	1.5 kHz	
Electrical Filter Roll-off	12 dB/octave	12 dB/octave	
Resonant Frequency	≥ 1,200 kcpm	≥ 20 kHz	[3]
Broadband Resolution(1 to 10,000 Hz)	1 mg rms	0.01 m/s ² rms	[3]
Non-Linearity	± 1 %	± 1 %	[4]
Transverse Sensitivity	≤ 5 %	≤ 5 %	
Environmental			
Overload Limit(Shock)	1,000 g pk	9,810 m/s ² pk	
Temperature Range	-320 to +250 °F	-196 to +121 °C	
Temperature Response	See Graph	See Graph	[3]
Electrical			
Settling Time(within 1% of bias)	≤ 3 sec	≤ 3 sec	
Discharge Time Constant	0.05 to 0.5 sec	0.05 to 0.5 sec	
Excitation Voltage	18 to 28 VDC	18 to 28 VDC	
Constant Current Excitation	1.6 to 20 mA	1.6 to 20 mA	
Output Impedance	≤ 100 Ohm	≤ 100 Ohm	
Output Bias Voltage	7 to 12 VDC	7 to 12 VDC	
Spectral Noise(1 Hz)	600 µg/√Hz	5,890 (µm/sec ²)/√Hz	
Spectral Noise(10 Hz)	120 µg/√Hz	1,180 (µm/sec ²)/√Hz	[3]
Spectral Noise(100 Hz)	36 µg/√Hz	355 (µm/sec ²)/√Hz	[3]
Spectral Noise(1 kHz)	25 µg/√Hz	250 (µm/sec ²)/√Hz	[3]
Spectral Noise(10 kHz)	6 µg/√Hz	59 (µm/sec ²)/√Hz	
Electrical Isolation	≥ 10 ⁸ Ohm	≥ 10 ⁸ Ohm	
Physical			
Size (Hex x Height)	7/8 in x 2.06 in	22 mm x 52.3 mm	
Weight	3.3 oz	94 gm	
Mounting Thread	1/4-28 Female	1/4-28 Female	[5]
Mounting Torque	2 to 5 ft-lb	2.7 to 6.8 Nm	
Sensing Element	Quartz	Quartz	
Sensing Geometry	Shear	Shear	
Housing Material	Stainless Steel	Stainless Steel	
Sealing	Hermetic	Hermetic	[6]
Electrical Connector	2-Pin MIL-C-5015	2-Pin MIL-C-5015	
Electrical Connection Position	Top	Top	

OPTIONAL VERSIONS

Optional versions have identical specifications and accessories as listed for the standard model except where noted below. More than one option may be used.

EX - Hazardous Area Approval- contact factory for specific approvals

M - Metric Mount
Supplied Accessory: Model M081A61 Mounting Stud 1/4-28 to M6 X 1 (1) replaces Model 081A40

NOTES:

- [1] Conversion Factor 1g = 9.81 m/s².
- [2] 1Hz = 60 cpm (cycles per minute).
- [3] Typical.
- [4] Zero-based, least-squares, straight line method.
- [5] 1/4-28 has no equivalent in S.I. units.
- [6] Design hydro tested to 1450 psi [10,000 kPa].
- [7] See Models's "Instructions for use" (IFU) for North American Conformity and Certification Statements

SUPPLIED ACCESSORIES:

Model 081A40 Mounting Stud (1)
Model ICS-6 NIST traceable single axis amplitude response calibration from 10 Hz to upper +/- 3dB point. (1)

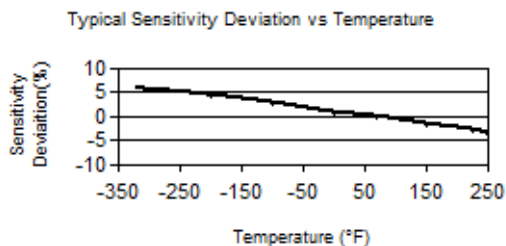

All specifications are at room temperature unless otherwise specified.
In the interest of constant product improvement, we reserve the right to change specifications without notice.
ICP® is a registered trademark of PCB Piezotronics, Inc.

Entered: ND	Engineer: BAM	Sales: EGY	Approved: JS	Spec Number:
Date: 01/23/2023	Date: 01/23/2023	Date: 01/23/2023	Date: 01/23/2023	69961

IMI SENSORS
A PCB PIEZOTRONICS DIV.
3425 Walden Avenue, Depew, NY 14043

Phone: 800-959-4464
Fax: 716-684-3823
E-Mail: imi@pcb.com

081-XXXX-90

PCB Piezotronics Inc. claims proprietary rights in the information disclosed hereon. Neither it nor any reproduction thereof will be disclosed to others without the written consent of PCB Piezotronics Inc.

STANDARD STUD MOUNT



MOUNTING THREAD	SEE DRAWING
5-40	A
M3 X 0.50	B
10-32	C
M5 X 0.80	D
1/4-28	E
M6 X 1.00	F

"A"
5-40
MOUNTING INSTRUCTIONS
(METRIC DIMENSIONS IN BRACKETS)



MOUNTING HOLE PREPARATION:
 1. $\phi .101 [\phi 2.57]$
 X $.20 [5.1] \nabla$ MIN.
 5-40 UNC-2B
 X $.15 [3.8] \nabla$ MIN.

4.) RECOMMENDED MOUNTING TORQUE,
 4-5 INCH POUNDS
 [45-55 NEWTON CENTIMETERS].

"B"
M3 X 0.50
MOUNTING INSTRUCTIONS
(ENGLISH DIMENSIONS IN BRACKETS)



MOUNTING HOLE PREPARATION:
 1. $\phi 2.5 [\phi .099]$
 X $4.6 [1.8] \nabla$ MIN.
 M3 X 0.50-6H
 X $3.3 [1.3] \nabla$ MIN.

4.) RECOMMENDED MOUNTING TORQUE,
 45-55 NEWTON CENTIMETERS
 [4-5 INCH POUNDS].

"C"
10-32
MOUNTING INSTRUCTIONS
(METRIC DIMENSIONS IN BRACKETS)



MOUNTING HOLE PREPARATION:
 1. $\phi .159 [\phi 4.04]$
 X $.23 [5.8] \nabla$ MIN.
 10-32 UNF-2B
 X $.15 [3.8] \nabla$ MIN.

4.) RECOMMENDED MOUNTING TORQUE,
 10-20 INCH POUNDS
 [113-225 NEWTON CENTIMETERS].

"D"
M5 X 0.80
MOUNTING INSTRUCTIONS
(ENGLISH DIMENSIONS IN BRACKETS)

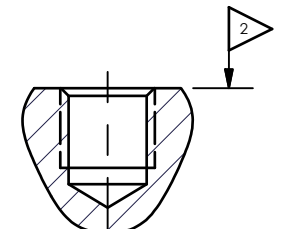

MOUNTING HOLE PREPARATION:
 1. $\phi 4.22 [\phi .166]$
 X $7.62 [300] \nabla$ MIN.
 M5 X 0.8-6H
 X $5.08 [200] \nabla$ MIN.

4.) RECOMMENDED MOUNTING TORQUE,
 113-225 NEWTON CENTIMETERS
 [10-20 INCH POUNDS].

REVISIONS		
REV	DESCRIPTION	DIN
R	CHANGED "B" HOLE TOLERANCE	53828

INTEGRAL STUD MOUNT



MOUNTING THREAD	SEE DRAWING
5-40	A
M3 X 0.50	B
10-32	C
M5 X 0.80	D
1/4-28	E
M6 X 1.00	F

"THRU-BOLT" STUD MOUNT



BOLT THREAD	SEE DRAWING
10-32	C
M5 X 0.80	D
1/4-28	E
M6 X 1.00	F
M8 X 1.25	F

"E"
1/4-28
MOUNTING INSTRUCTIONS
(METRIC DIMENSIONS IN BRACKETS)



MOUNTING HOLE PREPARATION:
 1. $\phi .218 [\phi 5.54]$
 X $.300 [7.62] \nabla$ MIN.
 1/4-28 UNF-2B
 X $.200 [5.08] \nabla$ MIN.

4.) RECOMMENDED MOUNTING TORQUE,
 2-5 FOOT POUNDS
 [3-7 NEWTON METERS].

"F"
M6 X 0.75, M6 X 1.00, M8 X 1.25
MOUNTING INSTRUCTIONS
(ENGLISH DIMENSIONS IN BRACKETS)



M6 X 0.75 MOUNTING HOLE PREPARATION:
 1. $\phi 5.31 [\phi .209]$
 X $7.62 [300] \nabla$ MIN.
 M6 X 0.75-6H
 X $5.08 [200] \nabla$ MIN.

M6 X 1.0 MOUNTING HOLE PREPARATION:
 1. $\phi 5.05 [\phi .199]$
 X $8.10 [320] \nabla$ MIN.
 M6 X 1.0-6H
 X $6.35 [250] \nabla$ MIN.

4.) RECOMMENDED MOUNTING TORQUE,
 3-7 NEWTON METERS [2-5 FT POUNDS].

M8 X 1.25 MOUNTING HOLE PREPARATION:
 1. $\phi 6.75 [\phi .266]$
 X $8.64 [340] \nabla$ MIN.
 M8 X 1.25-6H
 X $5.00 [197] \nabla$ MIN.

"G"
MOUNTING INSTRUCTIONS
FOR SPECIAL THREAD LENGTHS
(METRIC DIMENSIONS IN BRACKETS)



MOUNTING HOLE PREPARATION:
 1. ϕ DRILL DIA.
 X "C" ∇ MIN.
 TAP
 X "B" ∇ MIN.

THREAD DEPTH : B = X + 1 THREAD PITCH
 DRILL DEPTH : C = B + 3 THREAD PITCH
 SEE A-F FOR APPROPRIATE DRILL AND TAP
 THREAD PITCH = 1/TPI [P]

- 3.) FOR BEST RESULTS, PLACE A THIN LAYER OF SILICONE GREASE (OR EQUIVALENT) ON INTERFACE PRIOR TO MOUNTING.
- 2. MOUNTING SURFACE SHOULD BE FLAT TO WITHIN .001 (0.03) TIR OVER DIM 'A' WITH A $63 [1.61] \nabla$ OR BETTER FINISH FOR BEST RESULTS.
- 1. DRILL PERPENDICULAR TO MOUNTING SURFACE TO WITHIN $\pm 1^\circ$.

UNLESS OTHERWISE SPECIFIED TOLERANCES ARE:				DRAWN		CHECKED		ENGINEER	
DIMENSIONS IN INCHES		DIMENSIONS IN MILLIMETERS [IN BRACKETS]		NJF	05/03/23	JDM	05/03/23	MJN	05/03/23
DECIMALS XX $\pm .01$	DECIMALS X ± 0.3	DECIMALS XXX $\pm .005$	DECIMALS XX ± 0.13	TITLE					
CABLE TOLERANCES IN ENGLISH		CABLE TOLERANCES IN METRIC		INSTALLATION DRAWING					
1" \leq LENGTH < 1' = +1' / - 0		2.54cm \leq LENGTH < 30.5cm = +2.54cm / - 0		FOR STANDARD					
1' \leq LENGTH < 5' = +2' / - 0		30.5cm \leq LENGTH < 1.5m = +5.1cm / - 0		081 SERIES MOUNTING					
5' \leq LENGTH < 100' = +6' / - 0		1.5m \leq LENGTH < 30.5m = +15.2cm / - 0							
100' \leq LENGTH = +1' / - 0		30.5m \leq LENGTH = +30.5cm / - 0							
FILLETS AND RADII .003 - .005		FILLETS AND RADII 0.07 - 0.13							
				CODE IDENT. NO. 52681		DWG. NO. 081-XXXX-90		SCALE: NONE SHEET 1 OF 1	

PCB PIEZOTRONICS
 AN AMPHENOL COMPANY

3425 WALDEN AVE. DEPEW, NY 14043
 (716) 684-0001 E-MAIL: sales@pcb.com

PCB Piezotronics Inc. claims proprietary rights in the information disclosed hereon. Neither it nor any reproduction thereof will be disclosed to others without the written consent of PCB Piezotronics Inc.

REVISIONS		
REV	DESCRIPTION	DIN
NR	RELEASED TO DRAFTING	48898

62512

B

B

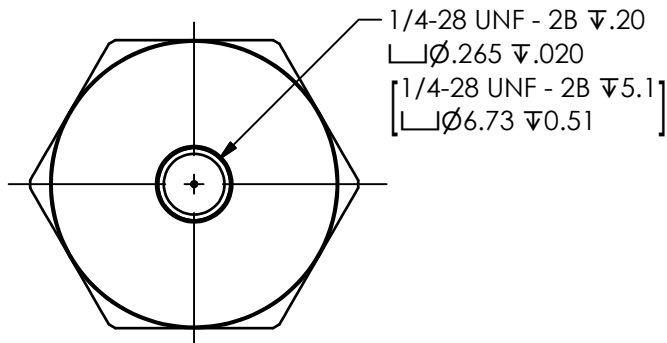
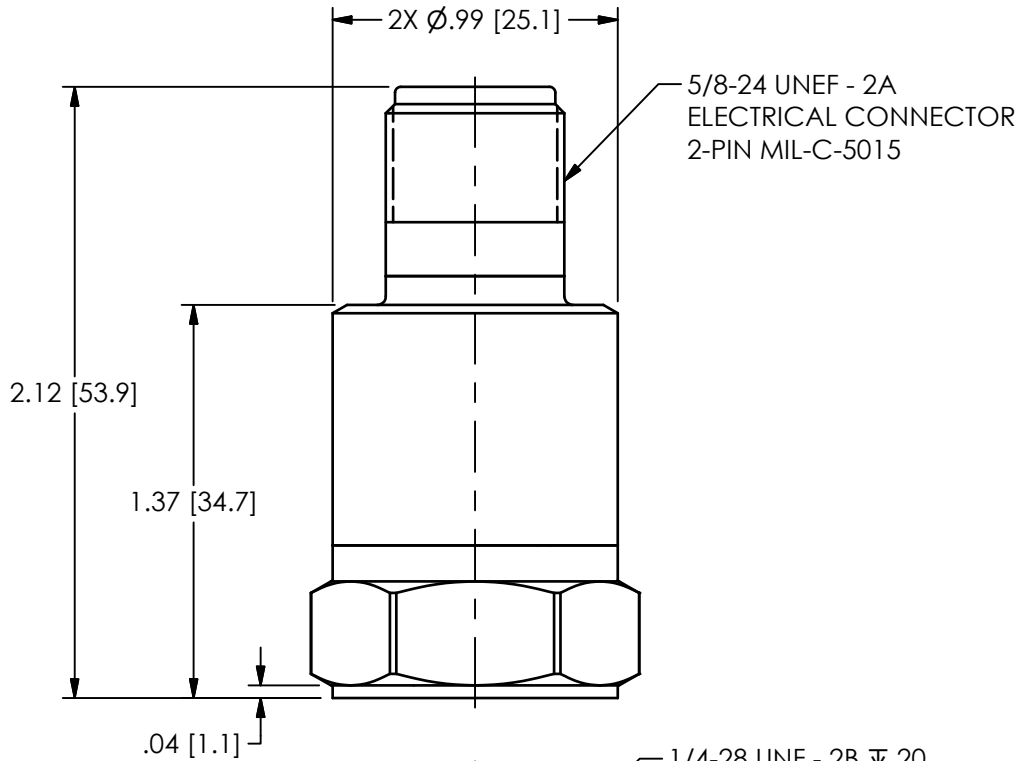
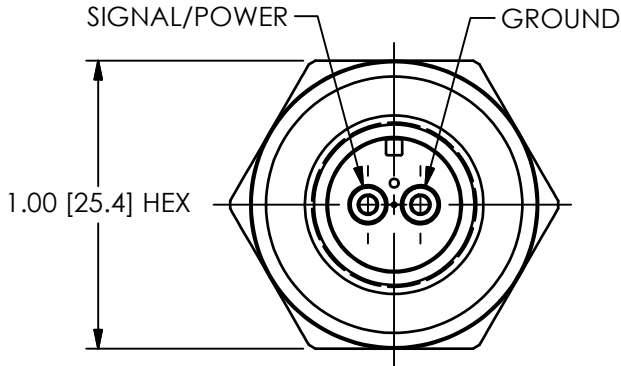

A

A

UNLESS OTHERWISE SPECIFIED TOLERANCES ARE:		DRAWN		CHECKED		ENGINEER		<p>3425 WALDEN AVE. DEPEW, NY 14043 (716) 684-0001 E-MAIL: sales@pcb.com</p>	
DIMENSIONS IN INCHES	DIMENSIONS IN MILLIMETERS [IN BRACKETS]	KRM	12/11/18	KRM	12/11/18	RMB	12/11/18		
DECIMALS XX ±.03 XXX ±.010	DECIMALS X ±.8 XX ±.25	TITLE OUTLINE DRAWING CASE ISOLATED CRYOGENIC ACCELEROMETER							CODE IDENT. NO. 52681
ANGLES ± 2 DEGREES	ANGLES ± 2 DEGREES								DWG. NO. 62512
FILLETS AND RADII .003 - .005	FILLETS AND RADII 0.07 - 0.13	SCALE: 1.5X		SHEET 1 OF 1					

This authorizes the application of the Certification Mark(s) shown below to the models described in the Product(s) Covered section when made in accordance with the conditions set forth in the Certification Agreement and Listing Report. This authorization also applies to multiple listee model(s) identified on the correlation page of the Listing Report.

This document is the property of Intertek Testing Services and is not transferable. The certification mark(s) may be applied only at the location of the Party Authorized To Apply Mark.

Applicant: PCB Piezotronics, Inc.
Address: 3425 Walden Ave
Depew, NY-14043-2417
Country: USA
Contact: Ms. Carrie Termin
Phone: 716-684-0002 ext. 2206
FAX: NA
Email: ctermin@pcb.com

Manufacturer: PCB Piezotronics, Inc.
Address: 3425 Walden Ave
Depew, NY-14043-2417
Country: USA
Contact: Ms. Carrie Termin
Phone: 716-684-0002 ext. 2206
FAX: NA
Email: ctermin@pcb.com

Party Authorized To Apply Mark: Same as Applicant
Report Issuing Office: Cortland, NY



Control Number: 5010230

Authorized by: _____

for L. Matthew Snyder, Certification Manager



This document supersedes all previous Authorizations to Mark for the noted Report Number.

This Authorization to Mark is for the exclusive use of Intertek's Client and is provided pursuant to the Certification agreement between Intertek and its Client. Intertek's responsibility and liability are limited to the terms and conditions of the agreement. Intertek assumes no liability to any party, other than to the Client in accordance with the agreement, for any loss, expense or damage occasioned by the use of this Authorization to Mark. Only the Client is authorized to permit copying or distribution of this Authorization to Mark and then only in its entirety. Use of Intertek's Certification mark is restricted to the conditions laid out in the agreement and in this Authorization to Mark. Any further use of the Intertek name for the sale or advertisement of the tested material, product or service must first be approved in writing by Intertek. Initial Factory Assessments and Follow up Services are for the purpose of assuring appropriate usage of the Certification mark in accordance with the agreement, they are not for the purposes of production quality control and do not relieve the Client of their obligations in this respect.

Intertek Testing Services NA Inc.
545 East Algonquin Road, Arlington Heights, IL 60005
Telephone 800-345-3851 or 847-439-5667 Fax 312-283-1672

Standard(s):	<p>Intrinsically Safe Apparatus And Associated Apparatus For Use In Class 1, 2, 3, Division 1, Hazardous (Classified) Locations [UL 913:2013 Ed.8+R:16Oct2015]</p> <p>Nonincendive Electrical Equipment For Use In Class I And II, Division 2 And Class III, Divisions 1 And 2 Hazardous (Classified) Locations [UL 121201:2017 Ed.9]</p> <p>Explosive Atmospheres – Part 0: Equipment – General Requirements [UL 60079-0:2013 Ed.6+R:20Oct2017]</p> <p>Explosive Atmospheres - Part 11: Equipment Protection By Intrinsic Safety 'i' [UL 60079-11:2013 Ed.6 +R:28Mar2014]</p> <p>Explosive Atmosphere – Part 15: Equipment Protection By Type Of Protection 'N' [UL 60079-15:2013 Ed.4+R:05May2017]</p> <p>Intrinsically Safe And Non-Incendive Equipment For Use In Hazardous Locations (R2016) [CSA C22.2#157:1992 Ed.3+G1;U2]</p> <p>Nonincendive Electrical Equipment For Use In Class I And II, Division 2 And Class III, Divisions 1 And 2 Hazardous (Classified) Locations [CSA C22.2#213:2017 Ed.3]</p>
Product:	<p>Cryogenic Accelerometers For Use In: Class I, Div. 1, GR A, B, C, D Class I, Div. 2, GR A, B, C, D Class II, Div. 1, GR E, F, G Class III Class I, Zone 0, AEx ia IIC T4 Ga Class I, Zone 2, AEx nA IIC T4 Gc -196°C ≤ Ta ≤ 121°C</p>
Brand Name:	<p>IMI Sensors a Division of PCB Piezotronic, IMI Vibration Sensors</p>
Models:	<p>EX637 Followed By A to Z; Followed By 00 to 999; Followed By A to Z. EXM637 Followed By A to Z; Followed By 00 to 999; Followed By A to Z. EX638 Followed By A to Z; Followed By 00 to 999; Followed By A to Z. EXM638 Followed By A to Z; Followed By 00 to 999; Followed By A to Z.</p>



СЕРТИФИКАТ СООТВЕТСТВИЯ

№ ЕАЭС RU C-US.AA87.B.00217/19

Серия **RU** № **0124866**



ОРГАН ПО СЕРТИФИКАЦИИ Орган по сертификации взрывозащищенного и рудничного оборудования (ОС ЦСВЭ) Общества с ограниченной ответственностью «Центр по сертификации взрывозащищенного и рудничного оборудования» (ООО «НАНИО ЦСВЭ»). Адрес места нахождения юридического лица: Россия, 140004, Московская область, Люберецкий район, город Люберцы, поселок ВУГИ, АО «Завод «ЭКОМАШ», литера В, Объект 6, этаж 3, офис 26. Адрес места осуществления деятельности в области аккредитации: Россия, 140004, Московская область, Люберецкий район, город Люберцы, поселок ВУГИ, АО «Завод «ЭКОМАШ», Литера В, Объект 6, этаж 3, офисы 26/3, 26/4, 26/5, 27/6, 30/1, 32. Аттестат № RA.RU.11AA87 от 20.07.2015 г. Телефон: +7 (495) 558-83-53, +7 (495) 558-82-44. Адрес электронной почты: ccve@ccve.ru

ЗАЯВИТЕЛЬ Общество с ограниченной ответственностью «Альфатех». Адрес места нахождения юридического лица: Россия, 125009, Москва, Малый Гнезниковский переулок, дом № 12, помещение I, комната 4. Адрес места осуществления деятельности: Россия, 127495, Москва, Долгопрудненское шоссе, дом № 3, Технопарк «Физтехпарк». ОГРН: 1167746393792. Телефон: +7 (495) 642-49-14. Адрес электронной почты: info@alphatechgroup.ru

ИЗГОТОВИТЕЛЬ PCB Piezotronics, Inc
Адрес места нахождения юридического лица и адрес места осуществления деятельности по изготовлению продукции: 3425 Walden Av., Depew, NY 14043, США

ПРОДУКЦИЯ Пьезоэлектрические преобразователи, вибропереключатели, предусилители с Ex-маркировкой согласно приложению (см. бланки №№ 0621345, 0621346, 0621347). Документы, в соответствии с которыми изготовлены изделия – см. приложение, бланк № 0621344. Серийный выпуск.

КОД ТН ВЭД ЕАЭС 9031 80 3800, 9026 20 2000, 8517 69 9000

СООТВЕТСТВУЕТ ТРЕБОВАНИЯМ
ТР ТС 012/2011 «О безопасности оборудования для работы во взрывоопасных средах».

СЕРТИФИКАТ СООТВЕТСТВИЯ ВЫДАН НА ОСНОВАНИИ
Протокола испытаний № 235.2019-Т от 11.09.2019 Испытательной лаборатории технических устройств Автономной некоммерческой организации «Национальный испытательный и научно-исследовательский институт оборудования для взрывоопасных сред» ИЛ Ex TU (аттестат № РОСС RU.0001.21МШ19 от 16.10.2015); Акта анализа состояния производства № 35-А/19 от 14.03.2019 Органа по сертификации взрывозащищенного и рудничного оборудования (ОС ЦСВЭ) Общества с ограниченной ответственностью «Центр по сертификации взрывозащищенного и рудничного оборудования» (ООО «НАНИО ЦСВЭ») (аттестат № RA.RU.11AA87 выдан 20.07.2015); Документов, представленных заявителем в качестве доказательства соответствия продукции требованиям ТР ТС 012/2011 (см. приложение, бланк № 0621344).
Схема сертификации – 1с.

ДОПОЛНИТЕЛЬНАЯ ИНФОРМАЦИЯ
Перечень стандартов, применяемых на добровольной основе для соблюдения требований ТР ТС 012/2011 (см. приложение, бланк № 0621344). Условия и срок хранения указаны в эксплуатационной документации. Назначенный срок службы – 10 лет.

СРОК ДЕЙСТВИЯ С 13.09.2019 ПО 12.09.2024
ВКЛЮЧИТЕЛЬНО

Руководитель (уполномоченное лицо) органа по сертификации

(подпись)

Залогин Александр Сергеевич

(Ф.И.О.)

Эксперт (эксперт-аудитор) (эксперты (эксперты-аудиторы))

(подпись)

М.П. Рафалович Борис Александрович

(Ф.И.О.)



ПРИЛОЖЕНИЕ

К СЕРТИФИКАТУ СООТВЕТСТВИЯ № ЕАЭС RU C-US.AA87.B.00217/19 Лист 1

Серия RU № 0621344

**I. ПЕРЕЧЕНЬ СТАНДАРТОВ, ПРИМЕНЯЕМЫХ НА ДОБРОВОЛЬНОЙ ОСНОВЕ
ДЛЯ СОБЛЮДЕНИЯ ТРЕБОВАНИЙ ТР ТС 012/2011 «О БЕЗОПАСНОСТИ ОБОРУДОВАНИЯ
ДЛЯ РАБОТЫ ВО ВЗРЫВООПАСНЫХ СРЕДАХ»**

Обозначение стандартов	Наименование стандартов
ГОСТ 31610.0-2014 (IEC 60079-0:2011)	Взрывоопасные среды. Часть 0. Оборудование. Общие требования
ГОСТ IEC 60079-1-2011	Взрывоопасные среды. Часть 1. Оборудование с видом взрывозащиты «взрывонепроницаемые оболочки «d»
ГОСТ 31610.11-2014 (IEC 60079-11:2011)	Взрывоопасные среды. Часть 11. Оборудование с видом взрывозащиты «искробезопасная электрическая цепь «i»
ГОСТ 31610.15-2012/МЭК 60079-15:2005	Электрооборудование для взрывоопасных газовых сред. Часть 15. Конструкция, испытания и маркировка электрооборудования с видом защиты «п»

**II. ДОКУМЕНТЫ, ПРЕДСТАВЛЕННЫЕ ЗАЯВИТЕЛЕМ В КАЧЕСТВЕ ДОКАЗАТЕЛЬСТВА
СООТВЕТСТВИЯ ПРОДУКЦИИ ТРЕБОВАНИЯМ ТР ТС 012/2011**

Руководства по эксплуатации: № 750119 от 23.01.19, № 830119 от 23.01.19, № 940219 от 07.02.19, № 630119 от 22.01.19, № 610119 от 22.01.19, № 910219 от 07.02.19, № 950219 от 08.02.19, № 970219 от 08.02.19.
Технические файлы: № 54202 от 02.02.2017, № 54204 от 02.02.2017, № 22438 С от 19.07.2012, № 62501 от 06.10.2016, № 33699 от 16.06.2016, № 56178 от 01.07.2016, № 70893 от 24.07.2019, № 54707 от 10.08.2016, № 48813 от 06.01.2011
Чертежи: № 47912 от 31.03.2017, № 49038 от 31.03.2017.
Перечень стандартов см. п. I.

III. ДОКУМЕНТЫ, В СООТВЕТСТВИИ С КОТОРЫМИ ИЗГОТОВЛЕНА ПРОДУКЦИЯ

Технические файлы: № 54202 от 02.02.2017, № 54204 от 02.02.2017, № 22438 С от 19.07.2012, № 62501 от 06.10.2016, № 33699 от 16.06.2016, № 56178 от 01.07.2016, № 70893 от 24.07.2019, № 54707 от 10.08.2016, № 48813 от 06.01.2011
Чертежи: № 47912 от 31.03.2017, № 49038 от 31.03.2017

Руководитель (уполномоченное
лицо) органа по сертификации

(подпись)

Эксперт (эксперт-аудитор)
(эксперты (эксперты-аудиторы))

(подпись)



Залогин Александр Сергеевич
(Ф.И.О.)

М.П.

Рафалович Борис Александрович
(Ф.И.О.)

ПРИЛОЖЕНИЕ

К СЕРТИФИКАТУ СООТВЕТСТВИЯ № ЕАЭС RU C-US.AA87.B.00217/19 Лист 2

Серия RU № 0621345

1. НАЗНАЧЕНИЕ И ОБЛАСТЬ ПРИМЕНЕНИЯ

Пьезоэлектрические преобразователи (далее – преобразователи) предназначены для контроля параметров вибрации, динамического давления и преобразования их в электрический сигнал.

Вибропереключатели предназначены для контроля уровня вибрации и защиты оборудования от повышенной вибрации.

Предусилители предназначены для преобразования зарядового сигнала в вольтовый.

Область применения - взрывоопасные зоны помещений и наружных установок согласно Ex-маркировке, ГОСТ IEC 60079-14-2013, регламентирующих применение во взрывоопасных средах.

2. СТРУКТУРНОЕ ОБОЗНАЧЕНИЕ

2.1. Преобразователи 176ХУУ/МZZZ-АА

X = от А до Z ревизия продукта, не влияющая на взрывозащиту

УУ = от 01 до 99 для индикации вариантов монтажа, диафрагмы, кабелей или разъемов

M = опционально для указания метрической длины кабеля

ZZZ = от 001 до 999 опционально для указания длины кабеля в футах: (не более 200 футов) или метрах: (не более 61 м)

AA = от 01 до 99 опционально для указания дробной длины кабеля в дюймах или сантиметрах, не влияющей на взрывозащиту

2.2. Преобразователи 351abcd

a – ревизия продукта, может быть: А,В,С,Д,Е,F,G,H,I,J,K,L или M, не влияющая на взрывозащиту

b – первая цифра вариации продукта, может быть: 0,1,2,3,4,5,6,7,8 или 9, не влияющая на взрывозащиту

c – вторая цифра вариации продукта, может быть: 0,1,2,3,4,5,6,7,8 или 9, не влияющая на взрывозащиту

d – третья цифра вариации продукта, может быть: 0,1,2,3,4,5,6,7,8,9 или отсутствует, не влияющая на взрывозащиту

2.3 Преобразователи EX(TO)(M)602yzzz1aaa, EX(TO)(M)603yzzz/aaa, EX(TO)(M)606yzzz/aaa, EX(TO)(M)607yzzz/aaa, EX(TO)(M)608yzzz/aaa, EX(M)637XYYYZ, (M)638XYYYZ

XX = TO (с температурным выходом), M (с метрической резьбой),

y = одна буква от А до Z, не влияющая на взрывозащиту

zzz = две или три цифры от 00 до 999, не влияющие на взрывозащиту

aaa = длина кабеля и/или тип разъема

2.4 Предусилители EX682XYYY

X – ревизия продукта (А,В ... М), не влияющая на взрывозащиту

YYY: параметры фильтрации, усиления, частотная характеристика, ... (от 1 до 999), не влияющие на взрывозащиту

2.5 Преобразователи EX(RV)(TO)(M)64хухх, EX(RV)(TO)(M)649ухх, EX (RV)(TO) (M)686ухх

XX = M (с метрической резьбой), TO (с температурным выходом), RV (с доп. вольтовым выходом).

Буквы х являются переменными цифрами (значения от 0 до 9), не влияющими на взрывозащиту

y = одна буква от А до Z, не влияющая на взрывозащиту

2.6 Преобразователи EX (XX) 622yzzz / aaa, EX (XX) 623yzzz / aaa, EX (XX) 625yzzz / aaa, EX (XX) 628yzzz / aaa

XX = HT (Высокотемпературная версия), M (с метрической резьбой), TO (с температурным выходом), VO (с выходом по скорости).

y = одна буква от А до Z, не влияющая на взрывозащиту

zzz = две или три цифры от 00 до 999, не влияющие на взрывозащиту

aaa = длина кабеля и/или тип разъема

2.7 Вибропереключатели 685ухх

Буквы х являются переменными цифрами (значения от 0 до 9), не влияющими на взрывозащиту

y = одна буква от А до Z, не влияющая на взрывозащиту

Руководитель (уполномоченное
лицо) органа по сертификации

(подпись)

Залогин Александр Сергеевич
(Ф.И.О.)

Эксперт (эксперт-аудитор)
(эксперты (эксперты-аудиторы))

(подпись)

Рафалович Борис Александрович
(Ф.И.О.)

ПРИЛОЖЕНИЕ

К СЕРТИФИКАТУ СООТВЕТСТВИЯ № ЕАЭС RU C-US.AA87.B.00217/19 Лист 3

Серия **RU** № **0621346**

3. ОСНОВНЫЕ ТЕХНИЧЕСКИЕ ДАННЫЕ

3.1. Ех-маркировка: преобразователей 176XYU/MZZ-AA	0Ex ia IIC T660°C...T6 Ga X
преобразователей 351abcd	0Ex ia IIC T4 Ga X
вибропереключателей 685yxx	1Ex d IIB+H ₂ T4 Gb
преобразователей EX(TO)(M)602yzzz1aaa, EX(TO)(M)603yzzz/aaa, EX(TO)(M)606yzzz/aaa, EX(TO)(M)607yzzz/aaa, EX(TO)(M)608yzzz/aaa	2Ex nA IIC T4 Gc X или 0Ex ia IIC T4 Ga X
преобразователей EX(M)637XYUZY, (M)638XYUZY	0Ex ia IIC T4 Ga X или 2Ex nA IIC T4 Gc X
предусилителей EX682XYUZY	0Ex ia IIC T4 Ga X или 2Ex nA IIC T4 Gc X
EX(RV)(TO)(M)64хyxx, EX(RV)(TO)(M)649yxx, EX (RV)(TO) (M)686yxx	1Ex d IIC T4 Gb X или 1Ex d IIC T3 Gb X
преобразователей EX (XX) 622yzzz / aaa, EX (XX) 623yzzz / aaa, EX (XX) 625yzzz / aaa , EX (XX) 628yzzz / aaa	2Ex nA IIC T4 Gc X
3.2. Диапазон температур окружающей среды, °С, преобразователей 176XYU/MZZ-AA	от -70 до 650
преобразователей 351abcd	от -196 до 121
вибропереключателей 685yxx	от -25 до 60
преобразователей EX(TO)(M)602yzzz1aaa, EX(TO)(M)603yzzz/aaa, EX(TO)(M)606yzzz/aaa, EX(TO)(M)607yzzz/aaa, EX(TO)(M)608yzzz/aaa	от -54 до 121
преобразователей EX(M)637XYUZY, (M)638XYUZY	от -196 до 121
предусилителей EX682XYUZY	от -40 до 85
преобразователей EX(RV)(TO)(M)64хyxx, EX(RV)(TO)(M)649yxx, EX (RV)(TO) (M)686yxx	от -20 до 80
преобразователей EX (XX) 622yzzz / aaa, EX (XX) 623yzzz / aaa, EX (XX) 625yzzz / aaa , EX (XX) 628yzzz / aaa	от -54 до 121

3.3. Входные искробезопасные электрические параметры преобразователей, предусилителей:

Модель	U _i , В	I _i , мА	P _i , Вт	C _i , нФ	L _i , мГн
преобразователей 176XYU/MZZ-AA	30	300	1	5	0,5
преобразователей 351abcd	28	200	1,2	61	305 мкГн
преобразователей EX(TO)(M)602yzzz1aaa, EX(TO)(M)603yzzz/aaa, EX(TO)(M)606yzzz/aaa, EX(TO)(M)607yzzz/aaa, EX(TO)(M)608yzzz/aaa	28	200	1	16,2 или 77,2 (с кабелем)	пренебрежимо мала или 305 мкГн (с учетом кабеля 305м)
преобразователей EX(M)637XYUZY, (M)638XYUZY	28	93	0,65	6,5	пренебрежимо мала
предусилителей EX682XYUZY	28	100	0,7	пренебрежимо мала	пренебрежимо мала

Руководитель (уполномоченное
лицо) органа по сертификации

(подпись)

Эксперт (эксперт-аудитор)
(эксперты (эксперты-аудиторы))

(подпись)

Залогин Александр Сергеевич

(Ф.И.О.)

М.П. Рафалович Борис Александрович

(Ф.И.О.)

ПРИЛОЖЕНИЕ

К СЕРТИФИКАТУ СООТВЕТСТВИЯ № ЕАЭС RU C-US.AA87.B.00217/19 Лист 4

Серия **RU** № **0621347**

3.4. Электрические параметры:

3.4.1 вибропереключателей 685ухх

Напряжение питания, В 85-245 (AC), 24 (DC)
 Максимальный ток, mA 150

3.4.2 преобразователей EX(TO)(M)602yzzz/aaa, EX(TO)(M)603yzzz/aaa, EX(TO)(M)606yzzz/aaa, EX(TO)(M)607yzzz/aaa, EX(TO)(M)608yzzz/aaa, EX (XX) 622yzzz / aaa, EX (XX) 623yzzz / aaa, EX (XX) 625yzzz / aaa, EX (XX) 628yzzz / aaa

с Ex-маркировкой 2Ex nA IIC T4 Gc X:

Напряжение питания, В 28
 Максимальный ток, mA 200
 Мощность, Вт 1

3.4.3 преобразователей EX(M)637XYYYZ, (M)638XYYYZ

Напряжение питания, В 18 – 28
 Максимальный ток, mA 1,6 – 20
 Мощность, Вт 0,5

3.4.4 Предусилителей EX682XYYY

Напряжение питания, В 22 – 28
 Максимальный ток, mA 3,1 – 4,1
 Мощность, Вт 0,1

3.4.5 преобразователей EX(RV)(TO)(M)64уххх, EX(RV)(TO)(M)649ухх, EX (RV)(TO) (M)686ухх

Напряжение питания, В 18 – 30
 Максимальный ток, mA 1,6 – 20
 Мощность, Вт 0,5

4. ОПИСАНИЕ КОНСТРУКЦИИ И СРЕДСТВ ОБЕСПЕЧЕНИЯ ВЗРЫВОЗАЩИЩЕННОСТИ

Преобразователи состоят из герметичного цилиндрического металлического корпуса, в котором размещается печатная плата и пьезокристаллический элемент. Сборка подключается к разъему или встроенному кабелю. На наружной поверхности корпуса преобразователя нанесена маркировка.

Вибропереключатели серии 685ухх выполнены в металлическом корпусе, внутри которого размещена электронная плата. На наружной поверхности корпуса нанесена маркировка.

Предусилители серии EX682XYYY выполнены в прямоугольном пластиковом корпусе с креплением на DIN рейку. Внутри корпуса размещена электронная плата. На корпусе размещен съемный клеммный блок. На наружной поверхности корпуса нанесена маркировка.

Подробное описание конструкции приведено в Руководствах по эксплуатации №750119 от 23.01.19, №830119 от 23.01.19, №940219 от 07.02.19, №630119 от 22.01.19, №610119 от 22.01.19, №910219 от 07.02.19, №950219 от 08.02.19, №970219 от 08.02.19

Взрывозащищенность преобразователей, вибропереключателей и предусилителей обеспечивается выполнением требований: ГОСТ 31610.15-2012/МЭК 60079-15:2005, ГОСТ 31610.0-2014 (IEC 60079-0:2011), ГОСТ IEC 60079-1-2011, ГОСТ 31610.11-2014 (IEC 60079-11:2011), в соответствии с Ex-маркировкой.

5. МАРКИРОВКА

Маркировка, наносимая на преобразователи, вибропереключатели и предусилители, включает следующие данные:

- товарный знак или наименование предприятия-изготовителя;
- серийный номер или номер партии;
- диапазон значений температур окружающей среды при эксплуатации;
- Ex-маркировку;
- специальный знак взрывобезопасности;
- наименование центра по сертификации и номер сертификата;
- предупредительные надписи;
- искробезопасные параметры

и другие данные, которые изготовитель должен отразить в маркировке, в соответствии с требованиями нормативной и технической документации.

6. СПЕЦИАЛЬНЫЕ УСЛОВИЯ ПРИМЕНЕНИЯ

5.1 Знак X, стоящий после Ex-маркировки, означает, что при эксплуатации преобразователей, вибропереключателей, предусилителей необходимо соблюдать следующие специальные условия:

- преобразователи, вибропереключатели, предусилители должны быть подключены к сертифицированному на соответствие требованиям ТР ТС 012/2011 источнику питания с соответствующей областью применения.

5.2 Свободные концы постоянно подсоединенного кабеля должны подключаться в сертифицированной на соответствие требованиям ТР ТС 012/2011 соединительной коробке или вне взрывоопасной зоны.

Специальные условия применения, обозначенные знаком X, отражены в сопроводительной документации, подлежащей обязательной поставке в комплекте с каждым изделием.

Внесение изменений в конструкцию изделий возможно только по согласованию с ОС ЦСВЭ в соответствии с требованиями ТР ТС 012/2011.

Руководитель (уполномоченное
лицо) органа по сертификации

Эксперт (эксперт-аудитор)
(эксперты (эксперты-аудиторы))

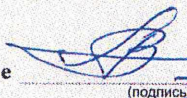
(подпись)

(подпись)

(подпись)



Залогин Александр Сергеевич

(ф.и.о.)

М.П. Рафалович Борис Александрович

(ф.и.о.)

TYPE EXAMINATION CERTIFICATE

Equipment or Protective System Intended for use in Potentially Explosive Atmospheres Directive
2014/34/EU

1. **Type Examination Certificate Number:** ITS19ATEX45016X Issue 00
2. **Product:** ACCELEROMETERS [EX(M)637XYYYY; EX(M)638XYYYY]
3. **Manufacturer:** PCB Piezotronics, Incorporated.
4. **Address:** 3425 Walden Avenue, Depew, NY 14043-2495, USA
5. This product and any acceptable variation thereto is specified in the schedule to this certificate and the documents therein referred to.
6. Intertek Testing and Certification Limited, certifies that this product has been found to comply with the Essential Health and Safety Requirements relating to the design and construction of the products intended for use in potentially explosive atmospheres given in Annex II of Directive 2014/34/EU of the European Parliament and of the Council, dated 26 February 2014.
7. Compliance with the Essential Health and Safety Requirements has been assured by compliance with EN 60079-0:2012+A11:2013 and EN 60079-15:2010 except in respect of those requirements referred to within item 14 of the Schedule
8. If the sign "X" is placed after the certificate number, it indicates that the product is subject to the special conditions of use specified in the Schedule to this certificate.
9. This Type Examination Certificate relates only to the design of the specified product and not to specific items subsequently manufactured.
10. The marking of the product shall include the following:



II 3 G Ex nA IIC T4 Gc
-196°C ≤ Ta ≤ +121°C

Certification Officer:

Kevin J. Wolf
Kevin J. Wolf

Date:

16 August 2019

SCHEDULE:

TYPE EXAMINATION CERTIFICATE NUMBER ITS19ATEX45016X Issue 00

11. Description of Equipment or Protective System

The products are Accelerometers with similar electronics.

EX(M)637XYYYZ Series Industrial ICP Accelerometer with Top exit connector

EX(M)638XYYYZ Series Industrial ICP Accelerometer with Side exit connector

The Accelerometers provide a voltage output when subjected to mechanical motion. They are intended to be fixed installation in the explosive atmosphere and to be supplied by:

field chosen/installed intrinsically safe barrier item for Ex ia

or

field chosen/installed supply item for Ex nA.

12. Report Number

Intertek Report: 103312845CRT-003a Dated: 8-August-2019.

13. Conditions of Certification

(a). Special Conditions of Use

- The apparatus must be only connect to an equipment whose electrical parameters are compatible with the electrical parameters. The apparatus shall be connected according to drawing 70910 (page 2/2). The connected cable and the connector must provide a minimum ingress protection of IP54, when assessed according to IEC 60079-0 and IEC 60079-15. Unused connector must be fitted with an appropriately rated blanking cover.

(b). Conditions of Manufacture - Routine Tests

- Dielectric Strength Test Per IEC 60079-15

14. Essential Health and Safety Requirements (EHSRs)

The relevant Essential Health and Safety Requirements (EHSRs) have been identified and assessed in Intertek Report: 103312845CRT-003a Dated: 8-August-2019.

SCHEDULE:

TYPE EXAMINATION CERTIFICATE NUMBER ITS19ATEX45016X Issue 00

15. Drawings and Documents

Title:	Drawing No.:	Rev. Level:	Date:
Technical File SECURITE INTRINSEQUE NON SPARK/ARC ATEX Ex ia ATEX Ex nA EX(M)637XYYYZ Series Industrial ICP Accelerometer EX(M)638XYYYZ Series Industrial ICP Accelerometer Page 1 of 2	70893	NR	7/24/2019
Technical File SECURITE INTRINSEQUE NON SPARK/ARC ATEX Ex ia ATEX Ex nA EX(M)637XYYYZ Series Industrial ICP Accelerometer EX(M)638XYYYZ Series Industrial ICP Accelerometer Page 2 of 2	70893	NR	7/24/2019
DESCRIPTIVE NOTICE FOR THE CERTIFICATION OF ACCELEROMETERS (ATEX Descriptive Notice) Page 1 of 1	70894	NR	07/24/19
AMPLIFIER ASSEMBLY Page 1 of 3	70895	NR	7/16/19
AMPLIFIER ASSEMBLY Page 2 of 3	70895	NR	7/16/19
AMPLIFIER ASSEMBLY Page 3 of 3	70895	NR	7/16/19
ETCHING DRAWING MODEL EX(M)637XYYYZ SERIES ETCHING DRAWING Page 1 of 2	70897	NR	8/8/19

15. Drawings and Documents (Continued)

Title:	Drawing No.:	Rev. Level:	Date:
ETCHING DRAWING MODEL EX(M)638XYYYY SERIES ETCHING DRAWING Page 2 of 2	70897	NR	8/8/19
APPROVAL INTERCONNECTION DIV 1, ZONE 0 Page 1 of 2	70910	NR	7/27/19
APPROVAL INTERCONNECTION DIV 2, ZONE 2 Page 2 of 2	70910	NR	7/27/19
INSTRUCTIONS FOR USE – EX(M)637XYYYY and EX(M)638XYYYY Series Page 1 of 3	70911	NR	08/01/19
INSTRUCTIONS FOR USE – EX(M)637XYYYY and EX(M)638XYYYY Series Page 2 of 3"	70911	NR	08/01/19
INSTRUCTIONS FOR USE – EX(M)637XYYYY and EX(M)638XYYYY Series Page 3 of 3"	70911	NR	08/01/19
APPROVAL XTAL DRAWING Page 1 of 1"	71165	NR	7/24/19



IECEX Certificate of Conformity

INTERNATIONAL ELECTROTECHNICAL COMMISSION IEC Certification Scheme for Explosive Atmospheres

for rules and details of the IECEX Scheme visit www.iecex.com

Certificate No.: IECEX ETL 19.0034X Issue No: 0 Certificate history:
Issue No. 0 (2019-08-22)

Status: **Current**

Page 1 of 3

Date of Issue: **2019-08-22**

Applicant: **PCB Piezotronics, Incorporated.**
3425 Walden Avenue, Depew, NY 14043-2495
United States of America

Equipment: **Accelerometers: EX(M)637XYYYY; EX(M)638XYYYY**
Optional accessory:

Type of Protection: **Intrinsic Safety 'ia' Non-Sparking 'nA'**

Marking:
Ex ia IIC T4 Ga
Ex nA IIC T4 Gc
-196° ≤ Ta ≤ 121°C
IECEX ETL 19.0034X

*Approved for issue on behalf of the IECEX
Certification Body:*

Kevin J. Wolf

Position:

Certification Officer

*Signature:
(for printed version)*

Date:

1. This certificate and schedule may only be reproduced in full.
2. This certificate is not transferable and remains the property of the issuing body.
3. The Status and authenticity of this certificate may be verified by visiting the [Official IECEX Website](http://www.iecex.com).

Certificate issued by:

Intertek
3933 US Route 11 South
Cortland NY 13045-2995
United States of America





IECEX Certificate of Conformity

Certificate No: IECEx ETL 19.0034X Issue No: 0
Date of Issue: **2019-08-22** Page 2 of 3
Manufacturer: **PCB Piezotronics, Incorporated.**
3425 Walden Avenue, Depew, NY 14043-2495
United States of America

Additional Manufacturing location(s):

This certificate is issued as verification that a sample(s), representative of production, was assessed and tested and found to comply with the IEC Standard list below and that the manufacturer's quality system, relating to the Ex products covered by this certificate, was assessed and found to comply with the IECEx Quality system requirements. This certificate is granted subject to the conditions as set out in IECEx Scheme Rules, IECEx 02 and Operational Documents as amended.

STANDARDS:

The apparatus and any acceptable variations to it specified in the schedule of this certificate and the identified documents, was found to comply with the following standards:

IEC 60079-0 : 2011 Explosive atmospheres - Part 0: General requirements
Edition:6.0
IEC 60079-11 : 2011 Explosive atmospheres - Part 11: Equipment protection by intrinsic safety "i"
Edition:6.0
IEC 60079-15 : 2010 Explosive atmospheres - Part 15: Equipment protection by type of protection "n"
Edition:4

*This Certificate **does not** indicate compliance with electrical safety and performance requirements other than those expressly included in the Standards listed above.*

TEST & ASSESSMENT REPORTS:

A sample(s) of the equipment listed has successfully met the examination and test requirements as recorded in

Test Report:

US/ETL/ExTR19.0041/00

Quality Assessment Report:

NL/DEK/QAR14.0004/02 NL/DEK/QAR14.0004/03



IECEX Certificate of Conformity

Certificate No: IECEx ETL 19.0034X

Issue No: 0

Date of Issue: **2019-08-22**

Page 3 of 3

Schedule

EQUIPMENT:

Equipment and systems covered by this certificate are as follows:

The products are Accelerometers with similar electronics.

EX(M)637XYYYZ Series Industrial ICP Accelerometer with Top exit connector

EX(M)638XYYYZ Series Industrial ICP Accelerometer with Side exit connector

The Accelerometers provide a voltage output when subjected to mechanical motion. They are intended to be fixed installation in the explosive atmosphere and to be supplied by field chosen/installed intrinsically safe barrier item.

When used in Zone 2

The Accelerometers provide a voltage output when subjected to mechanical motion. They are intended to be fixed installation in the explosive atmosphere and to be supplied by field chosen/installed supply item.

SPECIFIC CONDITIONS OF USE: YES as shown below:

Version Ex ia:

None

Version Ex nA:

The apparatus must be only connect to an equipment whose electrical parameters are compatible with the electrical parameters. The apparatus shall be connected according to drawing 70910 (page 2/2). The connected cable and the connector must provide a minimum ingress protection of IP54, when assessed according to IEC 60079-0 and IEC 60079-15. Unused connector must be fitted with an appropriately rated blanking cover.

Routine Dielectric testing in accordance with IEC 60079-15

Annex

[Annex 1 IECEx ETL 19.0034X.pdf](#)



IECEX Certificate of Conformity

Certificate No:	IECEX ETL 19.0034X	Issue No. 0
Annex No. 1		

Technical Documents			
Title:	Drawing No.:	Rev. Level:	Date:
*Technical File SECURITE INTRINSEQUE NON SPARK/ARC IECEX Ex ia IECEX Ex nA EX(M)637XYYYY Series Industrial ICP Accelerometer EX(M)638XYYYY Series Industrial ICP Accelerometer Page 1 of 2	70898	NR	7/24/2019
*Technical File SECURITE INTRINSEQUE NON SPARK/ARC IECEX Ex ia IECEX Ex nA EX(M)637XYYYY Series Industrial ICP Accelerometer EX(M)638XYYYY Series Industrial ICP Accelerometer Page 2 of 2	70898	NR	7/24/2019
*DESCRIPTIVE NOTICE FOR THE CERTIFICATION OF ACCELEROMETERS (IECEX Descriptive Notice) Page 1 of 1	70899	NR	07/24/19
*AMPLIFIER ASSEMBLY Page 1 of 3	70895	NR	7/16/19
*AMPLIFIER ASSEMBLY Page 2 of 3	70895	NR	7/16/19
*APPROVAL BOM	70895	NR	7/16/19

Certificate issued by:

Intertek
3933 US Route 11 South
Cortland NY 13045-2995
United States of America

intertek
Total Quality. Assured.



IECEX Certificate of Conformity

Certificate No:	IECEX ETL 19.0034X	Issue No. 0
Annex No. 1		

Technical Documents			
Title:	Drawing No.:	Rev. Level:	Date:
Page 3 of 3			
*APPROVAL ASSEMBLY EX(M)637XYYYY SERIES Page 1 of 2	70895	NR	7/16/19
* APPROVAL ASSEMBLY EX(M)638XYYYY SERIES Page 2 of 2	70895	NR	7/16/19
*ETCHING DRAWING MODEL EX(M)637XYYYY SERIES ETCHING DRAWING Page 1 of 2	70900	NR	8/8/19
*ETCHING DRAWING MODEL EX(M)638XYYYY SERIES ETCHING DRAWING Page 2 of 2	70900	NR	8/8/19
*APPROVAL INTERCONNECTION DIV 1, ZONE 0 Page 1 of 2	70910	NR	7/27/19
*APPROVAL INTERCONNECTION DIV 2, ZONE 2 Page 2 of 2	70910	NR	7/27/19
*INSTRUCTIONS FOR USE – EX(M)637XYYYY and EX(M)638XYYYY Series Page 1 of 3	70911	NR	08/01/19
*INSTRUCTIONS FOR USE – EX(M)637XYYYY and EX(M)638XYYYY Series	70911	NR	08/01/19

Certificate issued by:

Intertek
 3933 US Route 11 South
 Cortland NY 13045-2995
 United States of America

intertek
 Total Quality. Assured.



IECEX Certificate of Conformity

Certificate No:	IECEX ETL 19.0034X	Issue No. 0
Annex No. 1		

Technical Documents			
Title:	Drawing No.:	Rev. Level:	Date:
Page 2 of 3"			
*INSTRUCTIONS FOR USE – EX(M)637XXXXZ and EX(M)638XXXXZ Series Page 3 of 3"	70911	NR	08/01/19
*APPROVAL XTAL DRAWING Page 1 of 1"	71165	NR	7/24/19

*Note: An * is included before the title of documents that are new or revised.*

Certificate issued by:

Intertek
3933 US Route 11 South
Cortland NY 13045-2995
United States of America

intertek
Total Quality. Assured.

EU-TYPE EXAMINATION CERTIFICATE

Equipment or Protective System Intended for use in Potentially Explosive Atmospheres Directive
2014/34/EU

1. **EU-Type Examination Certificate Number:** ITS19ATEX25015 **Issue 00**
2. **Product:** ACCELEROMETERS [EX(M)637XYYYY; EX(M)638XYYYY]
3. **Manufacturer:** PCB Piezotronics, Incorporated.
4. **Address:** 3425 Walden Avenue, Depew, NY 14043-2495, USA
5. This product and any acceptable variation thereto is specified in the schedule to this certificate and the documents therein referred to.
6. Intertek Testing and Certification Limited, Notified Body number 0359 in accordance with Article 17 of Directive 2014/34/EU of the European Parliament and of the Council dated 26 February 2014, certifies that the product has been found to comply with the Essential Health and Safety Requirements relating to the design and construction of products intended for use in potentially explosive atmospheres given in Annex II of the Directive.
7. Compliance with the Essential Health and Safety Requirements has been assured by compliance with EN 60079-0:2012+A11:2013 and EN 60079-11:2012 except in respect of those requirements referred to within item 14 of the Schedule.
8. If the sign "X" is placed after the certificate number, it indicates that the product is subject to the special conditions of use specified in the Schedule to this certificate.
9. This EU-Type Examination Certificate relates only to the design and construction of the specified product. Further requirements of the Directive apply to the manufacturing process and supply of this product. These are not covered by this certificate.
10. The marking of the product shall include the following:



II 1 G Ex ia IIC T4 Ga
-196°C ≤ Ta ≤ +121°C

Certification Officer: _____

Kevin J. Wolf
Kevin J. Wolf

Date: _____

16 August 2019

SCHEDULE:

EU-Type Examination Certificate Number: ITS19ATEX25015 Issue 00

11. Description of Equipment or Protective System

The products are Accelerometers with similar electronics.

EX(M)637XYYYY Series Industrial ICP Accelerometer with Top exit connector

EX(M)638XYYYY Series Industrial ICP Accelerometer with Side exit connector

The Accelerometers provide a voltage output when subjected to mechanical motion. They are intended to be fixed installation in the explosive atmosphere and to be supplied by:

field chosen/installed intrinsically safe barrier item for Ex ia.

$U_i = 28V$, $I_i = 93mA$, $P_i = 0.65W$, $C_i = 6.5nF$, $L_i = 0H$

12. Report Number

Intertek Report: 103312845CRT-003a Dated: 8-August-2019.

13. Special Conditions of Certification

(a). Special Conditions of Use

- None

(b). Conditions of Manufacture - Routine Tests

- None

14. Essential Health and Safety Requirements (EHSRs)

The relevant Essential Health and Safety Requirements (EHSRs) have been identified and assessed in Intertek Report: 103312845CRT-003a Dated: 8-August-2019.

15. Drawings and Documents

Title:	Drawing No.:	Rev. Level:	Date:
Technical File SECURITE INTRINSEQUE NON SPARK/ARC ATEX Ex ia ATEX Ex nA EX(M)637XYYYY Series Industrial ICP Accelerometer EX(M)638XYYYY Series Industrial ICP Accelerometer Page 1 of 2	70893	NR	7/24/2019
Technical File SECURITE INTRINSEQUE NON SPARK/ARC ATEX Ex ia ATEX Ex nA EX(M)637XYYYY Series Industrial ICP Accelerometer EX(M)638XYYYY Series Industrial ICP Accelerometer Page 2 of 2	70893	NR	7/24/2019
DESCRIPTIVE NOTICE FOR THE CERTIFICATION OF ACCELEROMETERS (ATEX Descriptive Notice) Page 1 of 1	70894	NR	07/24/19
AMPLIFIER ASSEMBLY Page 1 of 3	70895	NR	7/16/19
AMPLIFIER ASSEMBLY Page 2 of 3	70895	NR	7/16/19
AMPLIFIER ASSEMBLY Page 3 of 3	70895	NR	7/16/19
ETCHING DRAWING MODEL EX(M)637XYYYY SERIES ETCHING DRAWING Page 1 of 2	70897	NR	8/8/19

15. Drawings and Documents (Continued)

Title:	Drawing No.:	Rev. Level:	Date:
ETCHING DRAWING MODEL EX(M)638XYYYZ SERIES ETCHING DRAWING Page 2 of 2	70897	NR	8/8/19
APPROVAL INTERCONNECTION DIV 1, ZONE 0 Page 1 of 2	70910	NR	7/27/19
APPROVAL INTERCONNECTION DIV 2, ZONE 2 Page 2 of 2	70910	NR	7/27/19
INSTRUCTIONS FOR USE – EX(M)637XYYYZ and EX(M)638XYYYZ Series Page 1 of 3	70911	NR	08/01/19
INSTRUCTIONS FOR USE – EX(M)637XYYYZ and EX(M)638XYYYZ Series Page 2 of 3"	70911	NR	08/01/19
INSTRUCTIONS FOR USE – EX(M)637XYYYZ and EX(M)638XYYYZ Series Page 3 of 3"	70911	NR	08/01/19
APPROVAL XTAL DRAWING Page 1 of 1"	71165	NR	7/24/19

EU Declaration of Conformity PS023

In Accordance with ISO/IEC 17050

Manufacturer:
 PCB Piezotronics, Inc.
 3425 Walden Avenue
 Depew, New York 14043
 USA

Authorized European Representative:
 PCB Piezotronics Europe GmbH
 Porschestrasse 20-30
 41836 Hückelhoven
 Germany

Certifies that type of equipment: ICP® Sensors

Whose Product Models Include: Y-Y1X-Xyxxx Series ICP Pressure Sensors
 Y-Y2X-Xyxxx Series ICP Force Sensors
 Y-Y3X-Xyxxx Series ICP Vibration Sensors
 Y-Y6X-Xyxxx Series ICP Industrial Vibration Sensors
 Y-Y74X-Xyxxx Series ICP Strain Sensors

Note: "Y-Y" is a placeholder for up to 6 possible letter prefixes depending on possible implemented options (letter prefixes may be part of the model number).
 "X-X" is a placeholder for one to five numbers.
 "y" is a place holder for one letter.
 "xxx" is a placeholder for up to three numbers and/or letters.

For example: HT622A01Industrial Vibe Sensor or WTLBM356A15 Vibration Sensor

These letters and numbers are included in the model numbers of the series. For details, see the related data sheets.

This declaration is applicable to all sensors of the above series, which have the CE mark on their data sheets and where those data sheets refer to this declaration of conformity. The data sheets for all model numbers referenced above, which include the CE mark on such data sheets and refer to this Declaration of Conformity are hereby incorporated by reference into this Declaration.

Conform to the following EU Directive(s) when installed per product documentation:

2014/30/EU
 2011/65/EU w/2015/863/EU

EMC Directive
 RoHS Directive

Harmonized Standards to which Conformity is Declared:

Harmonized Standards	EN 61326-1:2013 EN 61326-2-3:2013 EN 61010-1:2010 EN 61010-1:2010/A1:2019/AC:2019-04 EN 61010-1:2010/A1:2019 EN 63000:2018	Electrical Equipment for Measurement, Control and Laboratory Use- EMC requirements - Part 1: General requirements Electrical equipment for measurement, control and laboratory use - EMC requirements - Part 2-3: Particular requirements - Test configuration, operational conditions and performance criteria for transducers with integrated or remote signal conditioning Safety requirements for electrical equipment for measurement, control, and laboratory use - Part 1: General requirements Technical documentation for the assessment of electrical and electronic products with respect to the restriction of hazardous substances (IEC 63000:2016)
Emissions Test Standards	EN 55011:2016, EN 55011:2016/A1:2017 EN 55011:2016/A11:2020	Industrial, scientific and medical(ISM) radio frequency equipment Electromagnetic disturbance characteristics- Limits and methods of Measurement Class B

Immunity Test Standards	EN 61000-6-1:2007	Electromagnetic Compatibility (EMC) - Generic standards — Immunity for residential, commercial and light-industrial environments
	EN 61000-6-2:2005 EN 61000-6-2:2005/ AC:2005	Electromagnetic compatibility (EMC) — Part 6-2: Generic standards — Immunity for industrial environments
Test Reports	EMC Reports Safety Reports	GM29028c, GM29030c, GM29032c, GM29043c, GM29045c, GM29047c GM29029s, GM29031s, GM29033s, GM29044s, GM29046s, GM29048s

I, the undersigned, hereby declare that the equipment specified above conforms to the above Directive(s) Standard(s)

Place: Depew, NY **Date:** 1/5/2023

Signature:



Name: Wendy Willard

Title: Regulatory Affairs and Product Certification Specialist

UK Declaration of Conformity PS023UK

In Accordance with ISO/IEC 17050

Manufacturer:
 PCB Piezotronics, Inc.
 3425 Walden Avenue
 Depew, New York 14043
 USA

Authorized UK Representative:
 PCB Piezotronics Ltd
 Business and Technology Center
 Bessemer Drive
 Stevenage
 Hertfordshire, SG1 2DX
 United Kingdom



Certifies that type of equipment: ICP® Sensors

Whose Product Models Include: Y-Y1X-Xyxxx Series ICP Pressure Sensors
 Y-Y2X-Xyxxx Series ICP Force Sensors
 Y-Y3X-Xyxxx Series ICP Vibration Sensors
 Y-Y6X-Xyxxx Series ICP Industrial Vibration Sensors
 Y-Y74X-Xyxxx Series ICP Strain Sensors

Note: "Y-Y" is a placeholder for up to 6 possible letter prefixes depending on possible implemented options (letter prefixes may be part of the model number).
 "X-X" is a placeholder for one to five numbers.
 "y" is a place holder for one letter.
 "xxx" is a placeholder for up to three numbers and/or letters.

For example: HT622A01Industrial Vibe Sensor or WTLBM356A15 Vibration Sensor

These letters and numbers are included in the model numbers of the series. For details, see the related data sheets.

This declaration is applicable to all sensors of the above series, which have the UKCA mark on their data sheets and where those data sheets refer to this Declaration of Conformity. The data sheets for all model numbers referenced above, which include the UKCA mark on such data sheets and refer to this Declaration of Conformity are hereby incorporated by reference into this Declaration.

Conform to the following UK Statutory Requirements when installed per product documentation:

Electromagnetic Compatibility Regulations 2016 (SI 2016 No. 1091) Electrical Equipment (Safety) Regulations 2016
 The Restriction of the Use of Certain Hazardous Substances in Electrical and Electronic Equipment Regulations 2012 (SI 2012 No. 3032)

Designated Standards to which Conformity is Declared:

Harmonized Standards	EN 61326-1:2013 EN 61326-2-3:2013 EN 61010-1:2010 EN 61010-1:2010/A1:2019/AC:2019-04 EN 61010-1:2010/A1:2019 EN 63000:2018	Electrical Equipment for Measurement, Control and Laboratory Use- EMC requirements - Part 1: General requirements Electrical equipment for measurement, control and laboratory use - EMC requirements - Part 2-3: Particular requirements - Test configuration, operational conditions and performance criteria for transducers with integrated or remote signal conditioning Safety requirements for electrical equipment for measurement, control, and laboratory use - Part 1: General requirements Technical documentation for the assessment of electrical and electronic products with respect to the restriction of hazardous substances (IEC 63000:2016)
Emissions Test Standards	EN 55011:2016, EN 55011:2016/A1:2017 EN 55011:2016/A11:2020	Industrial, scientific and medical(ISM) radio frequency equipment Electromagnetic disturbance characteristics- Limits and methods of Measurement Class B

Immunity Test Standards	EN 61000-6-1:2007 EN 61000-6-2:2005 EN 61000-6-2:2005/ AC:2005	Electromagnetic Compatibility (EMC) - Generic standards — Immunity for residential, commercial and light-industrial environments Electromagnetic compatibility (EMC) — Part 6-2: Generic standards — Immunity for industrial environments
Test Reports	EMC Reports Safety Reports	GM29028c, GM29030c, GM29032c, GM29043c, GM29045c, GM29047c GM29029s, GM29031s, GM29033s, GM29044s, GM29046s, GM29048s

I, the undersigned, hereby declare that the equipment specified above conforms to the above Directive(s) Standard(s)

Place: Depew, NY **Date:** 1/5/2023

Signature:



Name: Wendy Willard

Title: Regulatory Affairs and Product Certification Specialist