



**Model EX1503M46**

**Pressure Transmitter, 5000 psi, CSA, ATEX, IECEx, ETL approved**

**Installation and Operating Manual**

**For assistance with the operation of this product,  
contact the PCB Piezotronics, Inc.**

**Toll-free: 716-684-0001**

**24-hour SensorLine: 716-684-0001**

**Fax: 716-684-0987**

**E-mail: [info@pcb.com](mailto:info@pcb.com)**

**Web: [www.pcb.com](http://www.pcb.com)**



## Repair and Maintenance

PCB guarantees Total Customer Satisfaction through its “Lifetime Warranty Plus” on all Platinum Stock Products sold by PCB and through its limited warranties on all other PCB Stock, Standard and Special products. Due to the sophisticated nature of our sensors and associated instrumentation, **field servicing and repair is not recommended and, if attempted, will void the factory warranty.**

Beyond routine calibration and battery replacements where applicable, our products require no user maintenance. Clean electrical connectors, housings, and mounting surfaces with solutions and techniques that will not harm the material of construction. Observe caution when using liquids near devices that are not hermetically sealed. Such devices should only be wiped with a dampened cloth—never saturated or submerged.

In the event that equipment becomes damaged or ceases to operate, our Application Engineers are here to support your troubleshooting efforts 24 hours a day, 7 days a week. Call or email with model and serial number as well as a brief description of the problem.

## Calibration

Routine calibration of sensors and associated instrumentation is necessary to maintain measurement accuracy. We recommend calibrating on an annual basis, after exposure to any extreme environmental influence, or prior to any critical test.

PCB Piezotronics is an ISO-9001 certified company whose calibration services are accredited by A2LA to ISO/IEC 17025, with full traceability to SI through N.I.S.T. In addition to our standard calibration services, we also offer specialized tests, including: sensitivity at elevated or cryogenic temperatures, phase response, extended high or low frequency response, extended range, leak testing, hydrostatic pressure testing, and others. For more information, contact your local PCB Piezotronics distributor, sales representative, or factory customer service representative.

## Returning Equipment

If factory repair is required, our representatives will provide you with a Return Material Authorization (RMA) number, which we use to reference any information you have already provided and expedite the repair process. This number should be clearly marked on the outside of all returned package(s) and on any packing list(s) accompanying the shipment.

## Contact Information

PCB Piezotronics, Inc.  
3425 Walden Ave.  
Depew, NY14043 USA  
Toll-free: (800) 828-8840  
24-hour SensorLine: (716) 684-0001  
General inquiries: [info@pcb.com](mailto:info@pcb.com)  
Repair inquiries: [rma@pcb.com](mailto:rma@pcb.com)

For a complete list of distributors, global offices and sales representatives, visit our website, [www.pcb.com](http://www.pcb.com).

## Safety Considerations

This product is intended for use by qualified personnel who recognize shock hazards and are familiar with the precautions required to avoid injury. While our equipment is designed with user safety in mind, the protection provided by the equipment may be impaired if equipment is used in a manner not specified by this manual.

Discontinue use and contact our 24-Hour Sensorline if:

- Assistance is needed to safely operate equipment
- Damage is visible or suspected
- Equipment fails or malfunctions

For complete equipment ratings, refer to the enclosed specification sheet for your product.

## Definition of Terms and Symbols

The following symbols may be used in this manual:



### DANGER

Indicates an immediate hazardous situation, which, if not avoided, may result in death or serious injury.

**CAUTION**

Refers to hazards that could damage the instrument.

**NOTE**

Indicates tips, recommendations and important information. The notes simplify processes and contain additional information on particular operating steps.

**The following symbols may be found on the equipment described in this manual:**



This symbol on the unit indicates that high voltage may be present. Use standard safety precautions to avoid personal contact with this voltage.



This symbol on the unit indicates that the user should refer to the operating instructions located in the manual.



This symbol indicates safety, earth ground.



PCB工业监视和测量设备 - 中国RoHS2公布表

PCB Industrial Monitoring and Measuring Equipment - China RoHS 2 Disclosure Table

部件名称	有害物质					
	铅 (Pb)	汞 (Hg)	镉 (Cd)	六价铬 (Cr(VI))	多溴联苯 (PBB)	多溴二苯醚 (PBDE)
住房	0	0	0	0	0	0
PCB板	X	0	0	0	0	0
电气连接器	0	0	0	0	0	0
压电晶体	X	0	0	0	0	0
环氧	0	0	0	0	0	0
铁氟龙	0	0	0	0	0	0
电子	0	0	0	0	0	0
厚膜基板	0	0	X	0	0	0
电线	0	0	0	0	0	0
电缆	X	0	0	0	0	0
塑料	0	0	0	0	0	0
焊接	X	0	0	0	0	0
铜合金/黄铜	X	0	0	0	0	0
本表格依据 SJ/T 11364 的规定编制。						
0：表示该有害物质在该部件所有均质材料中的含量均在 GB/T 26572 规定的限量要求以下。						
X：表示该有害物质至少在该部件的某一均质材料中的含量超出 GB/T 26572 规定的限量要求。						
铅是欧洲RoHS指令2011/65/ EU附件三和附件四目前由于允许的豁免。						

CHINA RoHS COMPLIANCE

Component Name	Hazardous Substances					
	Lead (Pb)	Mercury (Hg)	Cadmium (Cd)	Chromium VI Compounds (Cr(VI))	Polybrominated Biphenyls (PBB)	Polybrominated Diphenyl Ethers (PBDE)
Housing	O	O	O	O	O	O
PCB Board	X	O	O	O	O	O
Electrical Connectors	O	O	O	O	O	O
Piezoelectric Crystals	X	O	O	O	O	O
Epoxy	O	O	O	O	O	O
Teflon	O	O	O	O	O	O
Electronics	O	O	O	O	O	O
Thick Film Substrate	O	O	X	O	O	O
Wires	O	O	O	O	O	O
Cables	X	O	O	O	O	O
Plastic	O	O	O	O	O	O
Solder	X	O	O	O	O	O
Copper Alloy/Brass	X	O	O	O	O	O

This table is prepared in accordance with the provisions of SJ/T 11364.

O: Indicates that said hazardous substance contained in all of the homogeneous materials for this part is below the limit requirement of GB/T 26572.

X: Indicates that said hazardous substance contained in at least one of the homogeneous materials for this part is above the limit requirement of GB/T 26572.

Lead is present due to allowed exemption in Annex III or Annex IV of the European RoHS Directive 2011/65/EU.

# Installation and Operating Manual

Series 1500

## Pressure Transducers and Transmitters

Please review all instructions, specification sheet(s), and product literature prior to installing this product. Incorrect installation and/or operation may cause damage to the unit and void warranty.

For assistance with the operation of this product, contact:

**PCB PIEZOTRONICS INC. – PRESSURE DIVISION**

3425 Walden Avenue, Depew, New York 14043-2495 USA

Toll Free: 888-684-0011 Fax: 716-686-9129

24-Hour SensorLine<sup>SM</sup>: 716-684-0001

E-mail: [pressure@pcb.com](mailto:pressure@pcb.com)

Website: [www.pcb.com](http://www.pcb.com)

ISO 9001 CERTIFIED



OPERATION MANUAL FOR  
MODELS 1501, 1502 AND 1503  
PRESSURE TRANSDUCERS AND TRANSMITTERS

## 1.0 INTRODUCTION

The 1500 series Pressure Transducers/Transmitters are designed to provide a highly stable and accurate measurement of fluid (liquid and/or gas) pressure.

## 2.0 DESCRIPTION

All models utilize a sensing element that changes resistance in proportion to changes in applied strain, which is sensed by the force collecting passive diaphragm. This change in resistance is conditioned and amplified as needed to provide the required output and performance characteristics. Various electrical and mechanical interfaces are available.

## 3.0 INSTALLATION

Mechanical (please refer to the specification sheet supplied with each unit for pressure port configuration):

- Wrench only on the wrench flats for mounting or removing the unit. Do not use the housing or electrical termination for wrenching.
- The pressure cavity, unless otherwise specified, is manufactured with 17-4 and 316 stainless steels and is suitable for use with all media compatible with those materials.

Foreign objects (such as screwdrivers, etc) should not be introduced into the pressure cavity.

- To prevent performance degradation units must be protected from exposure to pressure transients and spikes that exceed the rated proof pressure range.

Electrical (please refer to the specification sheet supplied with each unit or the 1500 Series data sheet for specific wiring and excitation requirements):

- Units must have proper excitation to perform within specification. Insufficient power may prevent the unit from providing the full rated output at the full rated pressure.
- Electronics can be damaged by power surges. Surge arresters are recommended for applications where power surges are possible. (Mechanical isolation may also be required.)
- Electrical termination must be made in a NEMA 4 (or better) enclosure. Care must be taken to prevent migration of fluids into the cable jacket.

OPERATION MANUAL FOR  
MODELS 1501, 1502 AND 1503  
PRESSURE TRANSDUCERS AND TRANSMITTERS

- Unless otherwise specified, the unit's electronics should not be exposed to temperatures above 260° F.

#### **4.0 OPERATION**

When the unit is properly wired, powered and mounted it is ready for operation. (PCB offers various power supply solutions, consult factory or local representative for specifics.)

#### **5.0 POLARITY**

All units are designed to provide an increasing output with increasing pressure.

#### **6.0 CALIBRATION**

Each unit is provided with a calibration certificate. Calibration is verified via a 2-point calibration for an 0.5% accuracy and an 11- point calibration for 0.25% and 0.1% accuracies. If required, the internal or external shunt value will be recorded at 95% Full Scale Output ( $\pm 1\%$  Full Scale Output). Consult factory for other calibration or recalibration services.

#### **7.0 MAINTENANCE**

All PCB Pressure Transducers and Transmitters are engineered to be maintenance free to provide years of trouble free service.

The pressure cavity may be cleaned with cotton swabs and mild solvents. (No metallic objects or high-pressure sprays.)



Performance	ENGLISH	SI	
Measurement Range	5,000 psig	34,474 kPa	
Output	4-20 mA	4-20 mA	[1]
Accuracy	≤ .35 % FS	≤ .35 % FS	[2]
Linearity	≤ .25 % FS	≤ .25 % FS	
Hysteresis	≤ 0.2 % FS	≤ 0.2 % FS	
Repeatability	≤ 0.1 % FS	≤ 0.1 % FS	[3]
Zero Output Tolerance	± 0.3 % FS	± 0.3 % FS	[1]
Span Tolerance	± 0.3 % FS	± 0.3 % FS	[1]
Resolution	≤ 150 mpsi	≤ 1.03 kPa	[3]
Resonant Frequency	> 2 kHz	> 2 kHz	
<b>Environmental</b>			
Proof Pressure	2 x FS	2 x FS	
Burst Pressure	3 x FS	3 x FS	
Temperature Range(Operating)	-65 to +300 °F	-55 to +149 °C	
Temperature Range(Compensated)	-40 to +250 °F	-40 to +121 °C	
Thermal Error(Span)	± 2 % FS	± 2 % FS	[4]
Thermal Error(Zero Shift)	± 2 % FS	± 2 % FS	[4]
Acceleration Sensitivity(Maximum)(any direction)	≤ 0.005 %FS/g	≤ 0.05 % FS / (m/s <sup>2</sup> )	
Maximum Shock	1,000 g pk	9,800 m/s <sup>2</sup> pk	
Vibration Survivability	50 g pk	495 m/s <sup>2</sup> pk	
Hazardous Area Approval	See Manual	See Manual	
<b>Electrical</b>			
Supply Voltage	15 to 28 VDC	15 to 28 VDC	
Electrical Isolation(at 50 VDC)	> 100 MOhm	> 100 MOhm	
<b>Physical</b>			
Sensing Element	Foil Strain Gage (Full Bridge)	Foil Strain Gage (Full Bridge)	
Pressure Port	1/2-14 NPT	1/2-14 NPT	
Thread	External	External	
Dead Volume	0.3 in <sup>3</sup>	4,900 mm <sup>3</sup>	[3]
Wetted Parts Material	17-4 PH Stainless Steel	17-4 PH Stainless Steel	
Housing Material	304/304L Stainless Steel	304/304L Stainless Steel	
Electrical Connector	6-Pin Bayonet Jack	6-Pin Bayonet Jack	
Electrical Connections(Pin A)	Pos (+) Power/Signal	Pos (+) Power/Signal	
Electrical Connections(Pin D)	Neg (-) Power/Signal	Neg (-) Power/Signal	
Weight(without cable)	5.36 oz	152 gm	

**OPTIONAL VERSIONS**

Optional versions have identical specifications and accessories as listed for the standard model except where noted below. More than one option may be used.

**NOTES:**

[1]Adjustable.  
 [2]Combined least squares linearity, hysteresis and repeatability.  
 [3]Typical.  
 [4]Over compensated temperature range.  
 [5]See PCB Declaration of Conformance PS231 for details  
 [6]See Model's "Instructions For Use" (IFU) for North American Conformity and Certification Statements.



All specifications are at room temperature unless otherwise specified.  
 In the interest of constant product improvement, we reserve the right to change specifications without notice.  
 ICP® is a registered trademark of PCB Piezotronics, Inc.

Entered: ND	Engineer: RPF	Sales: DPC	Approved: RPF	Spec Number:
Date: 07/12/2022	Date: 07/12/2022	Date: 07/12/2022	Date: 07/12/2022	76577

**PCB PIEZOTRONICS**  
 AN AMPHENOL COMPANY

Phone: 716-684-0001  
 Fax: 716-684-0987  
 E-Mail: info@pcb.com

3425 Walden Avenue, Depew, NY 14043

69269

PCB Piezotronics Inc. claims proprietary rights in the information disclosed herein. Neither it nor any reproduction thereof will be disclosed to others without the written consent of PCB Piezotronics Inc.

**SCHEDULE DRAWING**

NO MODIFICATIONS PERMITTED WITHOUT REFERENCE TO THE NOTIFIED BODY

REVISIONS		
REV	DESCRIPTION	DIN
NR	RELEASED TO DRAFTING	52686

6. THE INSTALLER SHALL INSURE THAT THE TRANSDUCER MOUNTING STRUCTURE IS AT THE SAME GROUND POTENTIAL AS THE BARRIER GROUND. TOTAL EARTH LOOP IMPEDANCE SHALL BE LESS THAN 1 OHM. USE AN OFF GROUND TO THE SENSOR HOUSING IF A NON ISOLATION BARRIER IS USED.

5. CONNECTION METHOD TO THE EQUIPMENT SHOULD COMPLY WITH THE REQUIREMENT OF NEC AND CEC FOR NORTH AMERICAN CERTIFICATION.

4. SHIELDS TO BE EARTHED AT BARRIER END.

3. BARRIER WILL BE MOUNTED IN AN ENCLOSURE THE SUITABILITY OF WHICH WILL BE DETERMINED BY LOCAL AUTHORITIES. INSTALLATION IS CLASSIFIED HAZARDOUS LOCATION TO BE PERFORMED PER INSTALLATION REQUIREMENTS OF IECEx, ATEX, NEC, AND CEC.

NORTH AMERICA CERTIFICATION STANDARDS:  
 UL 913:2013 ED.8 +R:16OCT2015  
 UL 60079-0 ED.6 2013  
 UL 60079-11 ED.6 2013  
 CSA C22.2#60079-0:2015 ED.3  
 CSA C22.2#60079-11:2014 ED.2  
 CAN/CSA-22.2 NO. 157-92 (R2016)

2. ENTITY APPLICATION:

Barrier	I.S. Apparatus
$V_{oc}/U_o \leq$	$V_{MAX} / U_i$
$I_{sc}/I_o \leq$	$I_{MAX} / I_i$
$C_a/C_o >$	$C_i + C_{CABLE}$
$L_a/L_o >$	$L_i + L_{CABLE}$
$P_o \leq$	$P_i$ (CENELEC ONLY)

BARRIERS WITHIN THE SPECIFIED LIMITATIONS ARE PERMITTED.

ENTITY PARAMETERS

$U_i = 28$  V  
 $I_i = 100$  mA  
 $P_i = .65$  W  
 $C_i = 0$   
 $L_i = 2.4$  uH

CERTIFIED BY THE APPROPRIATE APPROVAL AUTHORITY FOR CONNECTION TO THE FOLLOWING AREAS:

NORTH AMERICA

ZONE 0  
 Ex ia IIC T4 Ga  
 AEx ia IIC T4 Ga  
 DIV 1  
 CLASS 1, GROUPS A,B,C,D T4

EUROPE

ZONE 0  
 Ex ia IIC T4 Ga

1. PART NO EX1503xyyy

NOTES: UNLESS OTHERWISE SPECIFIED.

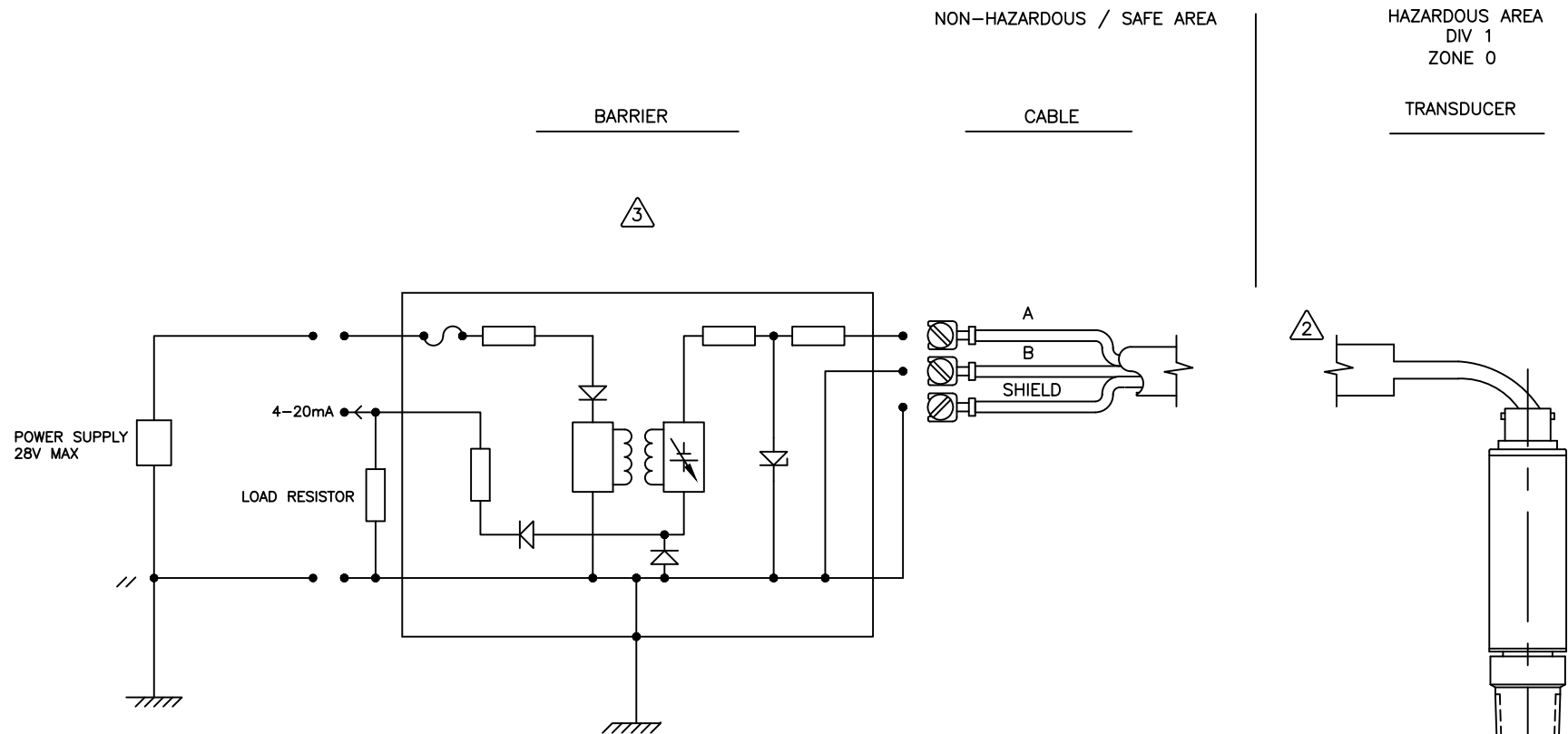

NO CHANGES WITHOUT INTERTEK APPROVAL

UNLESS OTHERWISE SPECIFIED	
DIMENSIONS ARE IN INCHES	
DECIMALS	X ± .05
	XX ± .01
	XXX ± .005
	XXXX ± .0005
ANGLES ± 2 DEGREES	
FILLETS AND RADII .003 - .005	
HEX DIMENSIONS ARE:	
	≤ .5 + .000 / - .003
	> .5 + .000 / - .005
INTERNAL THREAD DEPTH MIN.	
REMOVE ALL BURRS	
SHARP = R.000 - R.003	

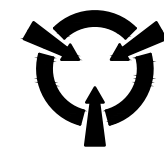

**CAUTION**  
 ELECTROSTATIC  
 DISCHARGE SENSITIVE

DRAWN		CHECKED		ENGINEER	
JJF	3/25/22	JJF	3/25/22	RF	3/25/22

TITLE  
**APPROVAL INTERCONNECTION**

**PCB PIEZOTRONICS**  
 AN AMPHENOL COMPANY  
 3425 WALDEN AVE. DEPEW, NY 14043  
 (716) 684-0002 E-MAIL: sales@pcb.com

CODE IDENT. NO. 52681	DWG. NO. <b>69269</b>
SCALE: NONE	SHEET 1 OF 2

69269

PCB Piezotronics Inc. claims proprietary rights in the information disclosed hereon. Neither it nor any reproduction thereof will be disclosed to others without the written consent of PCB Piezotronics Inc.

**SCHEDULE DRAWING**

NO MODIFICATIONS PERMITTED WITHOUT REFERENCE TO THE NOTIFIED BODY

REVISIONS		
REV	DESCRIPTION	DIN
	- SEE SHEET 1 -	

NON-HAZARDOUS / SAFE AREA  
OR DIV 2 / ZONE 2

POWER SUPPLY/  
SIGNAL CONDITIONER

CABLE

TRANSDUCER

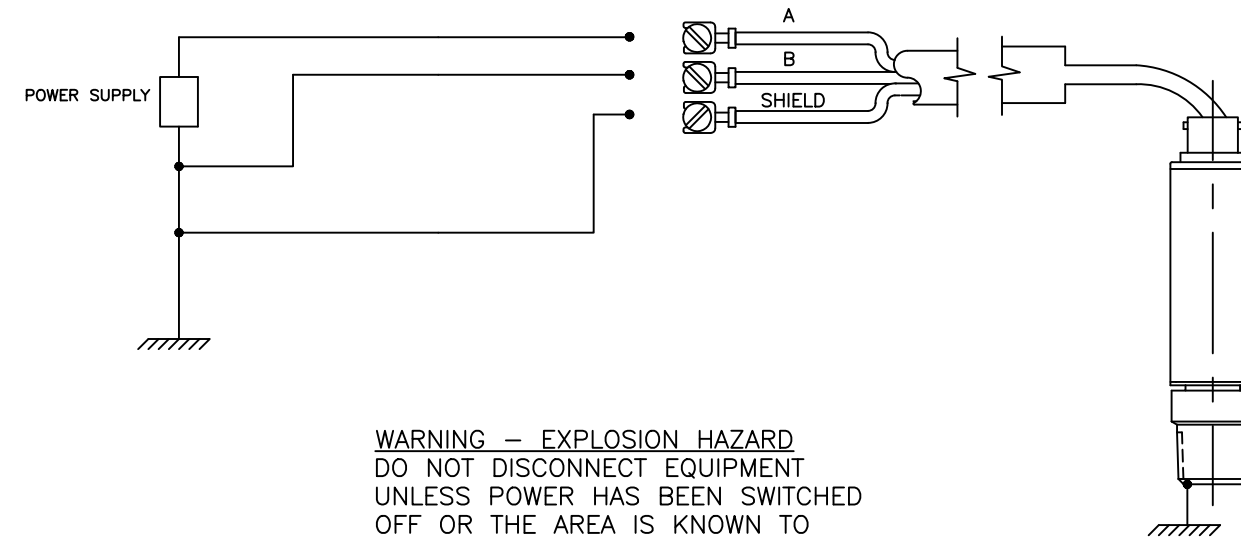

**WARNING – EXPLOSION HAZARD**  
DO NOT DISCONNECT EQUIPMENT  
UNLESS POWER HAS BEEN SWITCHED  
OFF OR THE AREA IS KNOWN TO  
BE NON-HAZARDOUS.

NO CHANGES WITHOUT INTERTEK APPROVAL

8. SHIELD TO BE EARTHED.
7. EQUIPMENT CONSISTS OF TRANSIENT PROTECTION DEVICE TO BE SET AT A LEVEL NOT EXCEEDING 140% OF RATED POWER SUPPLY VOLTAGE (30V).
6. INSTALL PER EN/IEC 60079-14 AND ALL LOCAL ELECTRICAL LAWS
5. FOR ZONE 2 INSTALLATION, POWER SUPPLY MUST BE CERTIFIED WITH ENTITY OUTPUT PARAMETERS (SEE PAGE 1 FOR POWER SUPPLY OUTPUT PARAMETERS)  
FOR U.S DIVISION 2 AND ZONE 2 INSTALLATION, POWER SUPPLY MUST BE APPROVED BY NRTL WITH ENTITY OUTPUT PARAMETERS (SEE PAGE 1 FOR POWER SUPPLY OUTPUT PARAMETERS)

ENTITY PARAMETERS:

U<sub>i</sub> = 28V  
I<sub>i</sub> = 100mA  
P<sub>i</sub> = .65W  
C<sub>i</sub> = 0  
L<sub>i</sub> = 2.4uH

4. FOR GUIDANCE ON CANADIAN INSTALLATION, REFER TO CEC PART I. FOR GUIDANCE ON U.S. INSTALLATION, INSTALL IN ACCORDANCE WITH NEC [ANSI/NFPA70] AND [ANSI/ISA RP12.6].
3. MAXIMUM VOLTAGE OF POWER SUPPLY/SIGNAL CONDITIONER NEVER TO EXCEED 250 Vrms.
2. CERTIFIED BY THE APPROPRIATE APPROVAL AUTHORITY FOR CONNECTION TO THE FOLLOWING AREAS:

NORTH AMERICA

ZONE 2

ExnA IIC T4 Gc  
AExnA IIC T4 Gc

DIV 2

CLASS 1, GROUPS A,B,C,D T4

EUROPE

ZONE 2

ExnA IIC T4 Gc

1. PART NO. IS EX1503xyyy

NOTES: UNLESS OTHERWISE SPECIFIED.

UNLESS OTHERWISE SPECIFIED DIMENSIONS ARE IN INCHES	
DECIMALS	X ± .05 XX ± .01 XXX ± .005 XXXX ± .0005
ANGLES ± 2 DEGREES FILLETS AND RADII .003 - .005	
HEX DIMENSIONS ARE: ≤ .5 + .000 / - .003 > .5 + .000 / - .005	
INTERNAL THREAD DEPTH MIN. REMOVE ALL BURRS SHARP = R.000 - R.003	

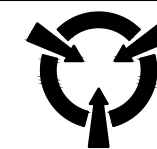

**CAUTION**  
ELECTROSTATIC  
DISCHARGE SENSITIVE

DRAWN		CHECKED		ENGINEER	
JJF	3/25/22	JJF	3/25/22	RF	3/25/22

TITLE  
**APPROVAL  
INTERCONNECTION**

**PCB PIEZOTRONICS**  
AN AMPHENOL COMPANY

3425 WALDEN AVE. DEPEW, NY 14043  
(716) 684-0002 E-MAIL: sales@pcb.com

CODE IDENT. NO. 52681  
DWG. NO. 69269

SCALE: NONE SHEET 2 OF 2

25757

PCB Piezotronics Inc. claims proprietary rights in the information disclosed hereon. Neither it, nor any reproduction thereof will be disclosed to others without written consent of PCB Piezotronics Inc.

APPLICATION		
NEXT ASS'Y	USED ON	VAR

REVISIONS				
REV	DESCRIPTION	ECN	DATE	APP'D
A	REVISED PER ECN	21010	11/11/04	<i>dm</i>

**Related Drawing**

No modifications permitted without the approval of the authorized person

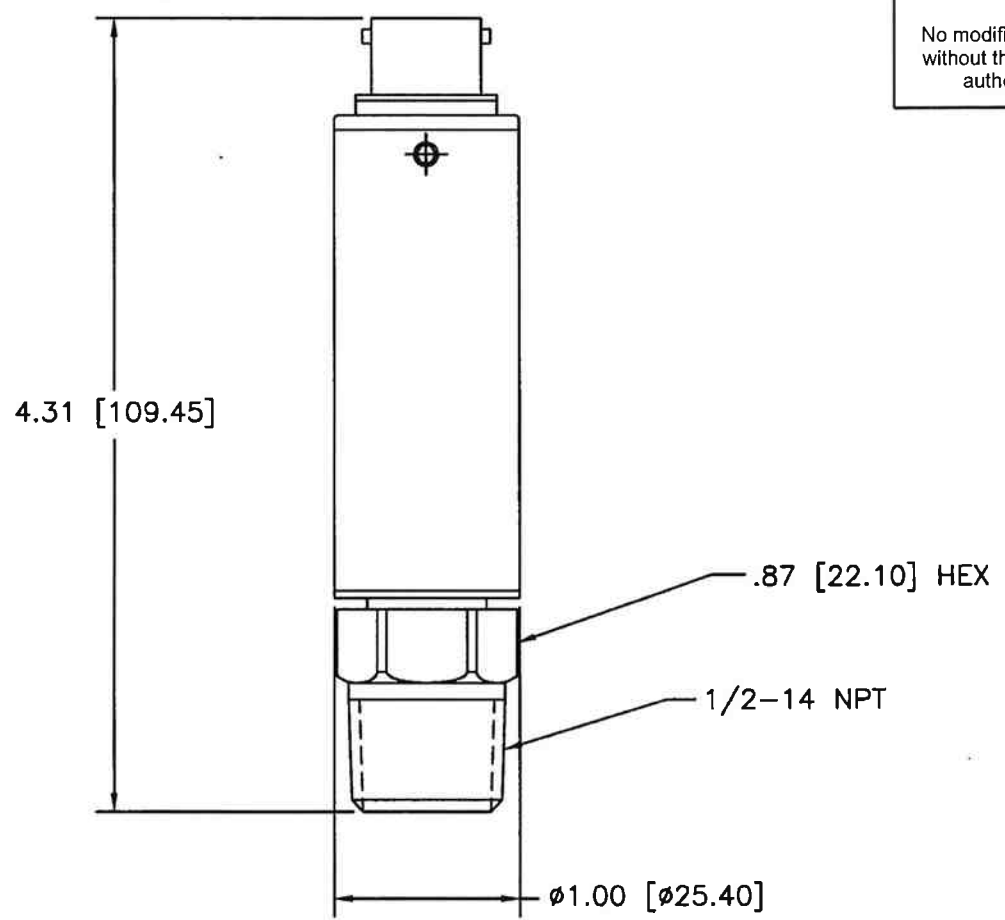

Ø.531 THRU  
Ø.703  
X .70<sup>+01</sup><sub>-00</sub> ▽  
TAP 1/2-14 NPT  
∇ 45° TO Ø.850

Ø.703 THRU  
TAP 1/2-14 NPT  
∇ 45° TO Ø.850

Ø.531 THRU  
Ø.703  
X .70<sup>+01</sup><sub>-00</sub> ▽  
TAP 1/2-14 NPT  
∇ 45° TO Ø.850

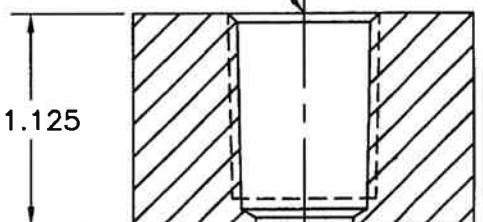
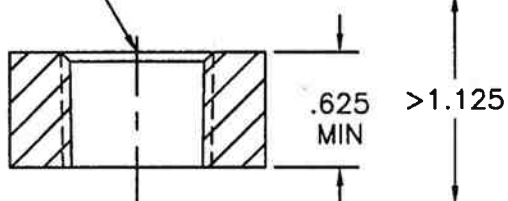
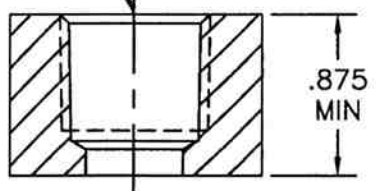

MODIFIED TAP INSTALLATION

UNLESS SPECIFIED TOLERANCES		DRAWN	<i>mde</i>	11/11/04	MFG	<i>P.R.R.</i>	11-15-04	<p>3425 WALDEN AVE. DEPEW, NY 14043 (716) 684-0001 EMAIL: SALES@PCB.COM</p>
DIMENSIONS IN INCHES	DIMENSIONS IN MILLIMETERS (IN BRACKETS)	CHK'D	<i>dm</i>	11/12/04	ENGR	<i>SM</i>	11/12/04	
DECIMALS XX ±.01	DECIMALS X ±0.3	APP'D	<i>JJD</i>	11/15/04	SALES	<i>DC</i>	11/12/04	CODE IDENT. NO. 52681
XXX ±.005	XX ±0.13	TITLE						DWG. NO.
ANGLES ±2 DEGREES	ANGLES ±2 DEGREES	INSTALLATION DRAWING						25757
FILLETS AND RADII .003 - .005	FILLETS AND RADII [0.07 - 0.13]	1500 SERIES						SCALE: FULL   SHEET 1 OF 1
DD011 REV. C 01/21/03		DC PRESSURE SENSOR						

# EU TYPE-EXAMINATION CERTIFICATE

1. EU type-examination Certificate (Module B)
2. Equipment or Protective System intended for use in potentially explosive atmospheres (Directive 2014/34/EU)



3. EU type examination certificate Nr **ITS-I21ATEX287031X R.0**

4. **Product:** EX1503 Series Pressure Sensor

5. **Manufacturer:** PCB Piezotronics, Inc.

**Applicant:** PCB Piezotronics, Inc.

6. **Address:** 3425 Walden Ave  
Depew, NY 14043; USA

**Address:** 3425 Walden Ave  
Depew, NY 14043; USA

7. This product and any acceptable variation thereto are specified in the schedule to this certificate and therein referred to.

8. INTERTEK ITALIA S.p.A., Notified Body n° 2575 in accordance with article 17 of the Directive 2014/34/EU of the European Parliament and Council of the 26 February 2014, certifies that the equipment or protective system has been found to comply with the essential Health and Safety Requirements relating to the design and construction of equipment and protective system intended for use in potentially explosive atmosphere, given in Annex II of the Directive.

The examination and tests results are recorded in confidential technical evaluation Intertek Report Nr. 103974085CRT-004a

9. Compliance with the Essential Health and Safety Requirements has been assured by compliance with EN IEC 60079-0:2018 and EN 60079-11:2012...except in respect of those requirements referred to at item 16 of the Schedule.

10. If the sign X is placed after the certificate number, it indicates that the product is subject to Special Conditions for Safe Use specified in the schedule to this certificate.

11. This EU-Type Examination Certificate relates only to the design and construction of the specified product. Further requirements of the Directive apply to the manufacturing process and supply of this product. These are not covered by this certificate.

12. The marking of the product shall include the following:



II 1 G  
Ex ia IIC T4 Ga  
Tamb: -40°C to +121°C

**Certificate issue date**

31 March 2021



**Todd L. Relyea**  
Certification Officer  
Intertek Italia S.p.A. (NB 2575)



PDR N° 277B

Membro degli Accordi di Mutuo Riconoscimento EA, IAF e ILAC

Signatory of EA, IAF and ILAC Mutual Recognition Agreements



This Certificate is for the exclusive use of Intertek's client and is provided pursuant to the agreement between Intertek and its Client. Intertek's responsibility and liability are limited to the terms and conditions of the agreement. Intertek assumes no liability to any party, other than to the Client in accordance with the agreement, for any loss, expense or damage occasioned by the use of this Certificate. Only the Client is authorized to permit copying or distribution of this Certificate and then only in its entirety. Any use of the Intertek name or one of its marks for the sale or advertisement of the tested material, product or service must first be approved in writing by Intertek.

**Intertek Italia S.p.A.** Via Miglioli, 2/A - 20063 Cernusco sul Naviglio, Milano - Italy

LFT-EMEA-IT-ATEX-OP-23a (29 August 2019)



## SCHEDULE

EU TYPE EXAMINATION CERTIFICATE NUMBER: ITS-I21ATEX287031X R.0

### 13. DESCRIPTION OF THE EQUIPMENT OR PROTECTIVE SYSTEM

The equipment covered by this certificate are PCB Pressure Sensors with strain gage sensing elements and built-in electronics. The equipment provides a 4-20mA current output when subjected to mechanical motion (pressure). These sensors are designed to be energy limited. The equipment ratings are  $U_i = 28V$ ,  $I_i = 100mA$ ,  $P_i = 0.65W$ ,  $C_i = 0F$ ,  $L_i = 2.4\mu H$ .

EX1503xyyy Series Pressure Sensors where:

x = A through Z Family Code;

yyy = 01 through 999 indicating variations in sensitivity, mounting thread or adaptor.

CE Marking shall be accompanied by the identification number of the Notified Body responsible for surveillance of production.

### 14. DRAWINGS AND DOCUMENTS

TITLE	DOCUMENT Nr	LEVEL	DATE
ATEX Technical File Intrinsic Safety (Sheets: 2)	34625	NR	April 9, 2018
Descriptive Notice For The Certification Of PCB Pressure Sensors	34626	NR	April 9, 2018
Approval Board Assembly	74229	NR	-
Etching Drawing	69272	NR	1/4/2021
Approval Schematic & BOM (Sheets: 2)	69297	NR	1/4/2021
Approval Assembly Model EX1503 Series	74226	NR	1/4/2021
Approval Interconnection (Sheets: 2)	69269	NR	1/4/2021
Instructions For Use – EX1503 Series Pressure Sensors (Sheets: 2)	69307	NR	-

Copies of the above listed documents are kept at Intertek Italia S.p.A. archive.

### 15. SPECIAL CONDITIONS FOR SAFE USE

The "ia" protected apparatus must only be connected to certified associated intrinsically safe equipment and this combination must be compatible regarding intrinsic safety rules.

### 16. ESSENTIAL HEALTH AND SAFETY REQUIREMENTS

The relevant essential Health and Safety Requirements have been identified and assessed in Intertek Report Nr. 103974085CRT-004a Revision 0 dated 05-January-2021.



**SCHEDULE**

**EU TYPE EXAMINATION CERTIFICATE NUMBER: ITS-I21ATEX287031X R.0**

**17. ROUTINE (FACTORY) TESTS**

None

# TYPE-EXAMINATION CERTIFICATE

1. Type-examination Certificate (Module A)
2. Equipment or Protective System intended for use in potentially explosive atmospheres (Directive 2014/34/EU)



3. Type examination certificate Nr **ITS-I21ATEX28703X R.0**

4. **Product:** EX1503 Series Pressure Sensors

5. **Manufacturer:** PCB Piezotronics, Inc.

**Applicant:** PCB Piezotronics, Inc.

6. **Address:** 3425 Walden Ave  
Depew, NY 14043  
USA

**Address:** 3425 Walden Ave  
Depew, NY 14043  
USA

7. This product and any acceptable variation thereto are specified in the schedule to this certificate and therein referred to.
8. INTERTEK ITALIA S.p.A., certifies that the equipment or protective system has been found to comply with the essential Health and Safety Requirements relating to the design and construction of equipment and protective system intended for use in potentially explosive atmosphere, given in Annex II of the Directive.

The examination and tests results are recorded in confidential technical evaluation Intertek Report Nr. 103974085CRT-004b.

9. Compliance with the Essential Health and Safety Requirements has been assured by compliance with EN IEC 60079-0:2018 and EN 60079-15:2010...except in respect of those requirements referred to at item 16 of the Schedule
10. If the sign X is placed after the certificate number, it indicates that the product is subject to Special Conditions for Safe Use specified in the schedule to this certificate.
11. This Type Examination Certificate relates only to the design and construction of the specified product. Further requirements of the Directive apply to the manufacturing process and supply of this product. These are not covered by this certificate.
12. The marking of the product shall include the following:



II 3 G  
Ex nA IIC T4 Gc  
Tamb: -40°C to +121°C

**Certificate issue date**

31 March 2021

  
Todd L. Relyea

**Todd L. Relyea**  
Certification Officer  
Intertek Italia S.p.A.



This Certificate is for the exclusive use of Intertek's client and is provided pursuant to the agreement between Intertek and its Client. Intertek's responsibility and liability are limited to the terms and conditions of the agreement. Intertek assumes no liability to any party, other than to the Client in accordance with the agreement, for any loss, expense or damage occasioned by the use of this Certificate. Only the Client is authorized to permit copying or distribution of this Certificate and then only in its entirety. Any use of the Intertek name or one of its marks for the sale or advertisement of the tested material, product or service must first be approved in writing by Intertek.

**Intertek Italia S.p.A.** Via Miglioli, 2/A - 20063 Cernusco sul Naviglio, Milano - Italy

LFT-EMEA-IT-ATEX-OP-23p (29 August 2019)





## SCHEDULE

TYPE EXAMINATION CERTIFICATE NUMBER: ITS-I21ATEX28703X R.0

### 13. DESCRIPTION OF THE EQUIPMENT OR PROTECTIVE SYSTEM

The equipment covered by this certificate are PCB Pressure Sensors with strain gage sensing elements and built-in electronics. The equipment provides a 4-20mA current output when subjected to mechanical motion (pressure). These sensors are designed to be energy limited. The equipment ratings are  $U_i = 28V$ ,  $I_i = 100mA$ ,  $P_i = 0.65W$ ,  $C_i = 0F$ ,  $L_i = 2.4\mu H$ .

EX1503xyyy Series Pressure Sensors where:

x = A through Z Family Code

yyy = 01 through 999 indicating variations in sensitivity, mounting thread or adaptor.

### 14. DRAWINGS AND DOCUMENTS

TITLE	DOCUMENT Nr	LEVEL	DATE
ATEX Technical File Non-Arcing (Sheets: 2)	34627	NR	April 9, 2018
Descriptive Notice For The Certification Of PCB Pressure Sensors	34628	NR	April 9, 2018
Approval Board Assembly	74229	NR	-
Etching Drawing	69272	NR	-
Approval Schematic & BOM (Sheets: 2)	69297	NR	1/4/2021
Approval Assembly Model EX1503 Series	74226	NR	1/4/2021
Approval Interconnection (Sheets: 2)	69269	NR	1/4/2021
Instructions For Use – EX1503 Series Pressure Sensors (Sheets: 2)	69307	NR	-

Copies of the above listed documents are kept at Intertek Italia S.p.A. archive.

### 15. SPECIAL CONDITIONS FOR SAFE USE

The apparatus must be only connected to an equipment whose electrical parameters are compatible with the electrical parameters. The apparatus shall be connected according to drawing 69269 (page 2/2). The connected cable and the connector must provide a minimum ingress protection of IP54, when assessed according to EN 60079-0 and EN60079-15. Unused connector must be fitted with an appropriately rated blanking cover.

### 16. ESSENTIAL HEALTH AND SAFETY REQUIREMENTS

The relevant essential Health and Safety Requirements have been identified and assessed in Intertek Report Nr. 103974085CRT-004b Revision 0 dated 103974085CRT-004b



## SCHEDULE

TYPE EXAMINATION CERTIFICATE NUMBER: ITS-I21ATEX28703X R.0

### 17. ROUTINE (FACTORY) TESTS

#### Dielectric Strength Test

- A routine dielectric strength test shall be carried out in accordance with Clause 23.2.1. Alternatively, a test shall be carried out at 1.2 times the test voltage but maintained for at least 100ms.

This authorizes the application of the Certification Mark(s) shown below to the models described in the Product(s) Covered section when made in accordance with the conditions set forth in the Certification Agreement and Listing Report. This authorization also applies to multiple listee model(s) identified on the correlation page of the Listing Report.

This document is the property of Intertek Testing Services and is not transferable. The certification mark(s) may be applied only at the location of the Party Authorized To Apply Mark.

**Applicant:** PCB Piezotronics Inc  
**Address:** 3425 Walden Ave  
Depew, NY 14043-2417  
**Country:** USA  
**Contact:** Carrie Termin  
**Phone:** (716) 684-0002 x2206  
**FAX:** NA  
**Email:** ctermin@pcb.com

**Manufacturer:** PCB Piezotronics Inc  
**Address:** 3425 Walden Ave  
Depew, NY 14043-2417  
**Country:** USA  
**Contact:** Carrie Termin  
**Phone:** (716) 684-0002 x2206  
**FAX:** NA  
**Email:** ctermin@pcb.com

**Party Authorized To Apply Mark:** Same as Manufacturer  
**Report Issuing Office:** Cortland, NY

**Control Number:** 5010230

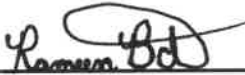
**Authorized by:**   
for L. Matthew Snyder, Certification Manager



This document supersedes all previous Authorizations to Mark for the noted Report Number.

This Authorization to Mark is for the exclusive use of Intertek's Client and is provided pursuant to the Certification agreement between Intertek and its Client. Intertek's responsibility and liability are limited to the terms and conditions of the agreement. Intertek assumes no liability to any party, other than to the Client in accordance with the agreement, for any loss, expense or damage occasioned by the use of this Authorization to Mark. Only the Client is authorized to permit copying or distribution of this Authorization to Mark and then only in its entirety. Use of Intertek's Certification mark is restricted to the conditions laid out in the agreement and in this Authorization to Mark. Any further use of the Intertek name for the sale or advertisement of the tested material, product or service must first be approved in writing by Intertek. Initial Factory Assessments and Follow up Services are for the purpose of assuring appropriate usage of the Certification mark in accordance with the agreement, they are not for the purposes of production quality control and do not relieve the Client of their obligations in this respect.

Intertek Testing Services NA Inc.  
545 East Algonquin Road, Arlington Heights, IL 60005  
Telephone 800-345-3851 or 847-439-5667 Fax 312-283-1672

	<p>Explosive Atmospheres - Part 0: Equipment - General Requirements [UL 60079-0:2019 Ed.7]</p> <p>Explosive Atmospheres — Part 0: Equipment — General Requirements [CSA C22.2#60079-0:2019 Ed.4]</p> <p>Explosive Atmospheres - Part 11: Equipment Protection By Intrinsic Safety "I" [UL 60079-11:2013 Ed.6]</p> <p>Explosive Atmospheres - Part 11: Equipment Protection By Intrinsic Safety "i" [CSA C22.2#60079-11:2014 Ed.2]</p> <p>Explosive Atmospheres - Part 15: Equipment Protection By Type Of Protection 'N' [UL 60079-15:2013 Ed.4+R:02Aug2013]</p> <p><b>Standard(s):</b></p> <p>Explosive Atmospheres - Part 15: Equipment Protection by Type of Protection "n" [CSA C22.2#60079-15:2016 Ed.2]</p> <p>Nonincendive Electrical Equipment for Use in Class I and II, Division 2 and Class III, Divisions 1 and 2 Hazardous (Classified) Locations [UL 121201:2017 Ed.9+R:26Aug2019]</p> <p>Nonincendive Electrical Equipment for Use in Class I and II, Division 2 and Class III, Divisions 1 and 2 Hazardous (Classified) Locations [CSA C22.2#213:2017 Ed.3+U1;U2]</p> <p>Intrinsically Safe Apparatus and Associated Apparatus for Use in Class I, II, and III, Division 1, Hazardous (Classified) Locations [UL 913:2013 Ed.8+R:06Dec2019]</p>
<p><b>Product:</b></p>	<p>1503 Series Pressure Sensor for use in:</p> <p>Class I, Division 1, Groups A, B, C and D  Class I, Zone 0, AEx ia, Ex ia IIC T4 Ga  Class I, Division 2, Groups A, B, C and D  Class I, Zone 2, AEx nA, Ex nA IIC T4 Gc</p> <p>Temperature Class: T4  Ambient Temperature Range: -40°C ≤ Tamb ≤ +121°C</p>
<p><b>Models:</b></p>	<p>EX1503', followed by one letter, followed by up to three numbers.</p>



# IECEX Certificate of Conformity

## INTERNATIONAL ELECTROTECHNICAL COMMISSION IEC Certification System for Explosive Atmospheres

for rules and details of the IECEx Scheme visit [www.iecex.com](http://www.iecex.com)

Certificate No.: **IECEX ETL 20.0037X** Page 1 of 4 [Certificate history:](#)

Status: **Current** Issue No: 0

Date of Issue: 2021-02-24

Applicant: **PCB Piezotronics, Inc.**  
3425 Walden Ave.  
Depew, NY 14043  
**United States of America**

Equipment: **EX1503 Series Pressure Sensor**

Optional accessory:

Type of Protection: **Intrinsic Safety "ia", Non arcing 'nA'**

Marking: Ex ia IIC T4 Ga  
Ex nA IIC T4 Gc  
-40°C ≤ Tamb ≤ +121°C  
IECEX ETL 20.0037X

Approved for issue on behalf of the IECEx  
Certification Body:

**Kevin J. Wolf**

Position:

**Certification Officer**

Signature:  
(for printed version)

Date:

2021-02-24

1. This certificate and schedule may only be reproduced in full.
2. This certificate is not transferable and remains the property of the issuing body.
3. The Status and authenticity of this certificate may be verified by visiting [www.iecex.com](http://www.iecex.com) or use of this QR Code.



Certificate issued by:

**Intertek**  
3933 US Route 11 South  
Cortland NY 13045-2995  
United States of America



# IECEx Certificate of Conformity

Certificate No.: **IECEx ETL 20.0037X**

Page 2 of 4

Date of issue: 2021-02-24

Issue No: 0

Manufacturer: **PCB Piezotronics, Inc.**  
3425 Walden Ave.  
Depew, NY 14043  
**United States of America**

Additional  
manufacturing  
locations:

This certificate is issued as verification that a sample(s), representative of production, was assessed and tested and found to comply with the IEC Standard list below and that the manufacturer's quality system, relating to the Ex products covered by this certificate, was assessed and found to comply with the IECEx Quality system requirements. This certificate is granted subject to the conditions as set out in IECEx Scheme Rules, IECEx 02 and Operational Documents as amended

## STANDARDS :

The equipment and any acceptable variations to it specified in the schedule of this certificate and the identified documents, was found to comply with the following standards

**IEC 60079-0:2017** Explosive atmospheres - Part 0: Equipment - General requirements  
Edition:7.0

**IEC 60079-11:2011** Explosive atmospheres - Part 11: Equipment protection by intrinsic safety "i"  
Edition:6.0

**IEC 60079-15:2010** Explosive atmospheres - Part 15: Equipment protection by type of protection "n"  
Edition:4

This Certificate **does not** indicate compliance with safety and performance requirements other than those expressly included in the Standards listed above.

## TEST & ASSESSMENT REPORTS:

A sample(s) of the equipment listed has successfully met the examination and test requirements as recorded in:

Test Reports:

[US/ETL/ExTR20.0043/00](#)

[US/ETL/ExTR20.0044/00](#)

Quality Assessment Report:

[NL/DEK/QAR14.0004/04](#)



# IECEx Certificate of Conformity

Certificate No.: **IECEx ETL 20.0037X**

Page 3 of 4

Date of issue: 2021-02-24

Issue No: 0

## **EQUIPMENT:**

Equipment and systems covered by this Certificate are as follows:

The equipment covered by this certificate are PCB Pressure Sensors with strain gage sensing elements and built-in electronics. The equipment provides a 4-20mA current output when subjected to mechanical motion (pressure). These sensors are designed to be energy limited. The equipment rating is 28 VDC. The equipment entity parameter ratings for 'ia' are  $U_i = 28V$ ,  $I_i = 100mA$ ,  $P_i = 0.65W$ ,  $C_i = 0F$ ,  $L_i = 2.4\mu H$ .

## **SPECIFIC CONDITIONS OF USE: YES as shown below:**

- The specific conditions for protection method "ia" is that a protected apparatus must only be connected to certified associated intrinsically safe equipment and this combination must be compatible regarding intrinsic safety rules.
- The specific conditions for protection method "nA" is connected cable and the connector must provide a minimum ingress protection of IP54, when assessed according to IEC 60079-0 and IEC 60079-15. Unused connector must be fitted with an appropriately rated blanking cover.
- The end user is to use and Ex certified IP 54 minimum plug with the socket.



# IECEx Certificate of Conformity

Certificate No.: **IECEx ETL 20.0037X**

Page 4 of 4

Date of issue: 2021-02-24

Issue No: 0

**Equipment (continued):**

EX1503xyyy Series Pressure Sensors where:

x = A through Z Family Code

yyy = 01 through 999 indicating variations in sensitivity, mounting thread or adaptor.

**Annex:**

[103974085CRT-001 - Annex for IECEx Certificate.pdf](#)





# Annex to IECEx Certificate of Conformity

<b>Certificate No:</b>	<b>IECEX ETL 20.0037X</b>	<b>Issue No. 0</b>
<b>Annex No. 1</b>		

<b>Technical Documents 'nA'</b>			
<b>Title:</b>	<b>Drawing No.:</b>	<b>Rev. Level:</b>	<b>Date:</b>
IECEX Technical File Non-Arcing (Sheets: 2)	69279	NR	April 9, 2018
Descriptive Notice For The Certification Of PCB Pressure Sensors	69277	NR	April 9, 2018
Approval Board Assembly	74229	NR	-
Etching Drawing	69272	NR	-
Approval Schematic & BOM (Sheets: 2)	69297	NR	1/4/2021
Approval Assembly Model EX1503 Series	74226	NR	1/4/2021
Approval Interconnection (Sheets: 2)	69269	NR	1/4/2021
Instructions For Use – EX1503 Series Pressure Sensors (Sheets: 2)	69307	NR	-

<b>Technical Documents 'ia'</b>			
<b>Title:</b>	<b>Drawing No.:</b>	<b>Rev. Level:</b>	<b>Date:</b>
IECEX Technical File Intrinsic Safety (Sheets: 2)	69278	NR	April 9, 2018
Descriptive Notice For The Certification Of PCB Pressure Sensors	69276	NR	April 9, 2018
Approval Board Assembly	74229	NR	-
Etching Drawing	69272	NR	1/4/2021
Approval Schematic & BOM (Sheets: 2)	69297	NR	1/4/2021
Approval Assembly Model EX1503 Series	74226	NR	1/4/2021
Approval Interconnection (Sheets: 2)	69269	NR	1/4/2021
Instructions For Use – EX1503 Series Pressure Sensors (Sheets: 2)	69307	NR	-

<b>Required Manufacturer Routine Testing</b>		
<b>Test</b>	<b>Title/Description of Test</b>	<b>Standard and Clause</b>
1	Dielectric Strength Test <ul style="list-style-type: none"> <li>A routine dielectric strength test shall be carried out in accordance with Clause 23.2.1. Alternatively, a test shall be carried out at 1.2 times the test voltage but maintained for at least 100ms.</li> </ul>	IEC 60079-15 Clause 23.2.1