

PCB Piezotronics Inc. claims proprietary rights in the information disclosed hereon. Neither it nor any reproduction thereof will be disclosed to others without the written consent of PCB Piezotronics Inc.

6449

REVISIONS		
REV	DESCRIPTION	DIN
E	UPDATED NOTES	54569

ABLATIVE INSTALLATION

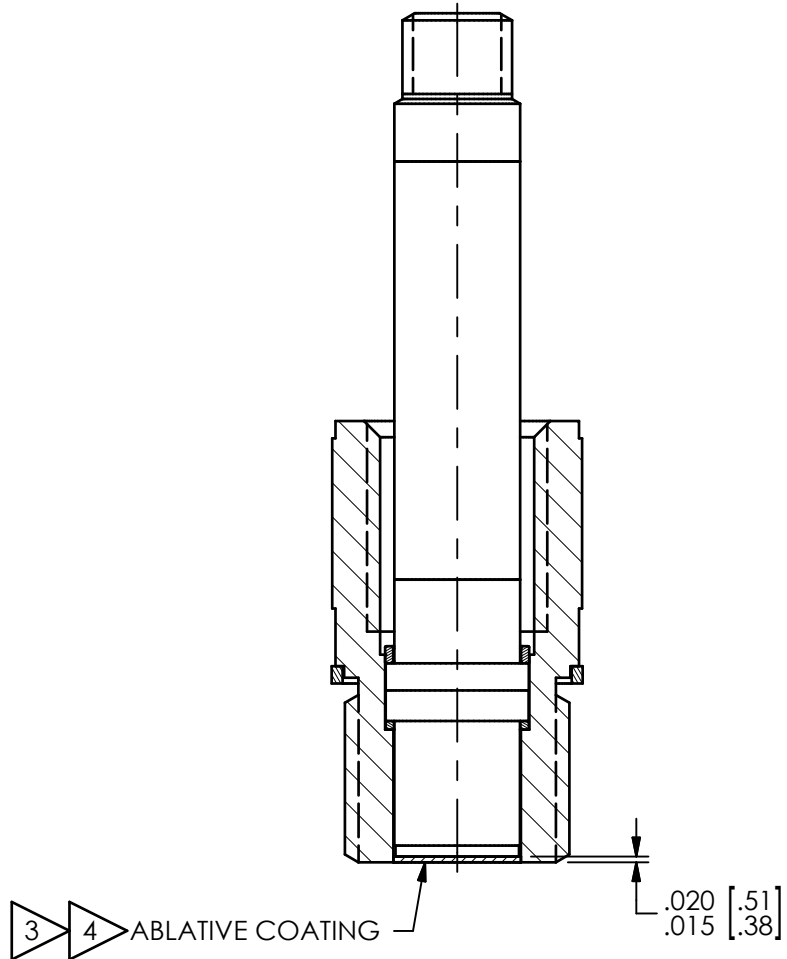

ELECTRICAL CONNECTOR  
10-32 UNF - 2A

5 MODEL 061A10  
ADAPTOR BODY  
MATERIAL: 17-4 PH

2 11mm HEX

MODEL 065A40  
BRASS SEAL (SUPPLIED)  
MODEL 065A34 (OPTIONAL)  
COPPER SEAL  
MODEL 065A35  
316 ST STL (OPTIONAL)

M10x1 - 6g

MODEL 060A03  
CLAMP NUT

LENGTH	
CHARGE	1.33±.05 [33.8]
ICP®	1.47±.05 [37.3]

.31 [7.9]      .34 [8.6]

MOUNTING HOLE PREPARATION:

M10x1 - 6H THRU

└┐∅.437±.001 [11.10±.03] ▽.030 [.76]

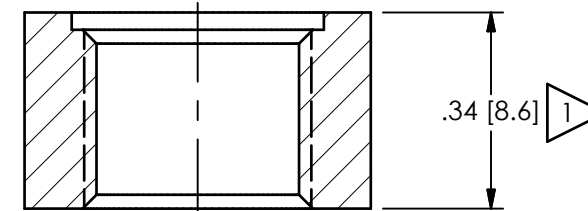

- 5 ADAPTOR MAY BE PURCHASED SEPARATELY: 061A10 (17-4PH) OR 061A11 (316L)
- 4 BLACK VINYL ELECTRICIANS TAPE HAS BEEN FOUND TO BE AN EFFECTIVE ABLATIVE MATERIAL, AS IS DC-4 SILICON GREASE
- 3 "CA" OPTION ONLY
- 2 MOUNTING TORQUE ON 11mm HEX: 5-8 FT-LBS [6.78-10.85 Nm]
- 1 ABOVE INSTALLATION SHOWN FOR WALL THICKNESS OF .34 [8.6]. └┐ THICKER WALLS ∅.75 [19.1] TO CLEAR 11mm HEX AND ALLOW FOR SOCKET WRENCH

UNLESS OTHERWISE SPECIFIED TOLERANCES ARE:		DRAWN		CHECKED		ENGINEER	
DIMENSIONS IN INCHES		NJF	02/02/24	JDM	02/02/24	MJB	02/02/24
DECIMALS XX ±.01 XXX ±.005		TITLE		INSTALLATION DRAWING MODELS (M)101A, (M)102A, (M)102B, & 061A10/A11 PRESSURE SENSOR			
ANGLES ± 2 DEGREES							
CABLE TOLERANCES IN ENGLISH							
CABLE TOLERANCES IN METRIC							
FILLETS AND RADII							

**PCB PIEZOTRONICS**  
AN AMPHENOL COMPANY

3425 WALDEN AVE. DEPEW, NY 14043  
(716) 684-0001 E-MAIL: sales@pcb.com

CODE IDENT. NO. 52681	SHEET B	DWG. NO. 6449
SCALE: 3X	SHEET 1 OF 1	