



Model 607M83
Industrial 3-Wire Accelerometer
Installation and Operating Manual

**For assistance with the operation of this product,
contact PCB Piezotronics, Inc.**

Toll-free: 800-959-4464
24-hour SensorLine: 716-684-0001
Fax: 716-684-3823
E-mail: imi@pcb.com
Web: www.imi-sensors.com



Repair and Maintenance

PCB guarantees Total Customer Satisfaction through its “Lifetime Warranty Plus” on all Platinum Stock Products sold by PCB and through its limited warranties on all other PCB Stock, Standard and Special products. Due to the sophisticated nature of our sensors and associated instrumentation, **field servicing and repair is not recommended and, if attempted, will void the factory warranty.**

Beyond routine calibration and battery replacements where applicable, our products require no user maintenance. Clean electrical connectors, housings, and mounting surfaces with solutions and techniques that will not harm the material of construction. Observe caution when using liquids near devices that are not hermetically sealed. Such devices should only be wiped with a dampened cloth—never saturated or submerged.

In the event that equipment becomes damaged or ceases to operate, our Application Engineers are here to support your troubleshooting efforts 24 hours a day, 7 days a week. Call or email with model and serial number as well as a brief description of the problem.

Calibration

Routine calibration of sensors and associated instrumentation is necessary to maintain measurement accuracy. We recommend calibrating on an annual basis, after exposure to any extreme environmental influence, or prior to any critical test.

PCB Piezotronics is an ISO-9001 certified company whose calibration services are accredited by A2LA to ISO/IEC 17025, with full traceability to SI through N.I.S.T. In addition to our standard calibration services, we also offer specialized tests, including: sensitivity at elevated or cryogenic temperatures, phase response, extended high or low frequency response, extended range, leak testing, hydrostatic pressure testing, and others. For more information, contact your local PCB Piezotronics distributor, sales representative, or factory customer service representative.

Returning Equipment

If factory repair is required, our representatives will provide you with a Return Material Authorization (RMA) number, which we use to reference any information you have already provided and expedite the repair process. This number should be clearly marked on the outside of all returned package(s) and on any packing list(s) accompanying the shipment.

Contact Information

PCB Piezotronics, Inc.
3425 Walden Ave.
Depew, NY14043 USA
Toll-free: (800) 828-8840
24-hour SensorLine: (716) 684-0001
General inquiries: info@pcb.com
Repair inquiries: rma@pcb.com

For a complete list of distributors, global offices and sales representatives, visit our website, www.pcb.com.

Safety Considerations

This product is intended for use by qualified personnel who recognize shock hazards and are familiar with the precautions required to avoid injury. While our equipment is designed with user safety in mind, the protection provided by the equipment may be impaired if equipment is used in a manner not specified by this manual.

Discontinue use and contact our 24-Hour Sensorline if:

- Assistance is needed to safely operate equipment
- Damage is visible or suspected
- Equipment fails or malfunctions

For complete equipment ratings, refer to the enclosed specification sheet for your product.

Definition of Terms and Symbols

The following symbols may be used in this manual:



DANGER

Indicates an immediate hazardous situation, which, if not avoided, may result in death or serious injury.

**CAUTION**

Refers to hazards that could damage the instrument.

**NOTE**

Indicates tips, recommendations and important information. The notes simplify processes and contain additional information on particular operating steps.

The following symbols may be found on the equipment described in this manual:



This symbol on the unit indicates that high voltage may be present. Use standard safety precautions to avoid personal contact with this voltage.



This symbol on the unit indicates that the user should refer to the operating instructions located in the manual.



This symbol indicates safety, earth ground.



PCB工业监视和测量设备 - 中国RoHS2公布表

PCB Industrial Monitoring and Measuring Equipment - China RoHS 2 Disclosure Table

部件名称	有害物质					
	铅 (Pb)	汞 (Hg)	镉 (Cd)	六价铬 (Cr(VI))	多溴联苯 (PBB)	多溴二苯醚 (PBDE)
住房	0	0	0	0	0	0
PCB板	X	0	0	0	0	0
电气连接器	0	0	0	0	0	0
压电晶体	X	0	0	0	0	0
环氧	0	0	0	0	0	0
铁氟龙	0	0	0	0	0	0
电子	0	0	0	0	0	0
厚膜基板	0	0	X	0	0	0
电线	0	0	0	0	0	0
电缆	X	0	0	0	0	0
塑料	0	0	0	0	0	0
焊接	X	0	0	0	0	0
铜合金/黄铜	X	0	0	0	0	0
本表格依据 SJ/T 11364 的规定编制。						
0：表示该有害物质在该部件所有均质材料中的含量均在 GB/T 26572 规定的限量要求以下。						
X：表示该有害物质至少在该部件的某一均质材料中的含量超出 GB/T 26572 规定的限量要求。						
铅是欧洲RoHS指令2011/65/ EU附件三和附件四目前由于允许的豁免。						

CHINA RoHS COMPLIANCE

Component Name	Hazardous Substances					
	Lead (Pb)	Mercury (Hg)	Cadmium (Cd)	Chromium VI Compounds (Cr(VI))	Polybrominated Biphenyls (PBB)	Polybrominated Diphenyl Ethers (PBDE)
Housing	O	O	O	O	O	O
PCB Board	X	O	O	O	O	O
Electrical Connectors	O	O	O	O	O	O
Piezoelectric Crystals	X	O	O	O	O	O
Epoxy	O	O	O	O	O	O
Teflon	O	O	O	O	O	O
Electronics	O	O	O	O	O	O
Thick Film Substrate	O	O	X	O	O	O
Wires	O	O	O	O	O	O
Cables	X	O	O	O	O	O
Plastic	O	O	O	O	O	O
Solder	X	O	O	O	O	O
Copper Alloy/Brass	X	O	O	O	O	O

This table is prepared in accordance with the provisions of SJ/T 11364.

O: Indicates that said hazardous substance contained in all of the homogeneous materials for this part is below the limit requirement of GB/T 26572.

X: Indicates that said hazardous substance contained in at least one of the homogeneous materials for this part is above the limit requirement of GB/T 26572.

Lead is present due to allowed exemption in Annex III or Annex IV of the European RoHS Directive 2011/65/EU.

Model Number
607M83

INDUSTRIAL 3-WIRE ACCELEROMETER

Revision: C
ECN #: 49794

	ENGLISH	SI	
Performance			
Sensitivity(± 20 %)	100 mV/g	10.2 mV/(m/s ²)	[1]
Measurement Range(12 VDC)	± 50 g	± 490 m/s ²	[2]
Measurement Range(5 VDC)	± 15 g	± 147 m/s ²	[2]
Frequency Range(± 3 dB)	90 to 600,000 cpm	1.5 to 10,000 Hz	
Resonant Frequency	1,500 kcpm	25 kHz	[2]
Broadband Resolution(1 to 10,000 Hz)	2 mg	19.6 mm/s ²	[2]
Non-Linearity	± 1 %	± 1 %	[3]
Transverse Sensitivity	≤ 7 %	≤ 7 %	
Environmental			
Overload Limit(Shock)	5,000 g pk	49,050 m/s ² pk	
Temperature Range	-65 to +250 °F	-54 to +121 °C	
Temperature Response	See Graph	See Graph	[2]
Enclosure Rating	IP68	IP68	
Electrical			
Settling Time(within 1% of bias)	≤ 5.0 sec	≤ 5.0 sec	
Discharge Time Constant	≥ 0.1 sec	≥ 0.1 sec	
Excitation Voltage	5 to 12 VDC	5 to 12 VDC	
Output Impedance	< 100 Ohm	< 100 Ohm	
Current Draw	0.5 mA	0.5 mA	
Output Bias Voltage	2.5 to 6 VDC	2.5 to 6 VDC	
Spectral Noise(10 Hz)	18 µg/√Hz	176.6 (µm/sec ²)/√Hz	[2]
Spectral Noise(100 Hz)	4 µg/√Hz	39.2 (µm/sec ²)/√Hz	[2]
Spectral Noise(1 kHz)	2 µg/√Hz	19.6 (µm/sec ²)/√Hz	[2]
Electrical Isolation(Case)	> 10 ⁸ Ohm	> 10 ⁸ Ohm	
Physical			
Size - Hex	9/16 in	14 mm	
Size - Height	0.97 in	24.6 mm	
Weight(without cable)	1.1 oz	31 gm	[4]
Mounting	Stud	Stud	
Mounting Thread	1/4-28 Male	No Metric Equivalent	[5]
Mounting Torque(Stud)	7 to 8 ft-lb	9.5 to 10.8 Nm	[6][7]
Mounting Torque(hex nut)	2 to 5 ft-lb	2.7 to 6.8 Nm	
Sensing Element	Ceramic	Ceramic	
Sensing Geometry	Shear	Shear	
Housing Material	Stainless Steel	Stainless Steel	
Sealing	Welded Hermetic	Welded Hermetic	
Electrical Connector	Molded Integral Cable	Molded Integral Cable	
Electrical Connection Position	Side	Side	
Cable Termination	Blunt cut	Blunt cut	
Electrical Connections(Red)	Pos (+) Power	Pos (+) Power	
Electrical Connections(Black)	Ground	Ground	
Electrical Connections(White)	Acceleration Output	Acceleration Output	
Cable Length	10 ft	3.0 m	
Cable Type	Polyurethane	Polyurethane	

OPTIONAL VERSIONS

Optional versions have identical specifications and accessories as listed for the standard model except where noted below. More than one option may be used.

M - Metric Mount
Supplied Accessory: Model M080A159 Mounting stud, 1/2-20 to M6 x 1

NOTES:

- [1] Conversion Factor 1g = 9.81 m/s².
- [2] Typical.
- [3] Zero-based, least-squares, straight line method.
- [4] Measured with mounting stud.
- [5] 1/4-28 has no equivalent in S.I. units.
- [6] 1/8" hex Allen key required for English version, 4 mm hex Allen key required for Metric version.
- [7] Stud torque must exceed sensor hex nut torque to ensure proper dismantling.

SUPPLIED ACCESSORIES:

Model ICS-2 NIST-traceable single-point amplitude response calibration at 6000 cpm (100 Hz) for each axis (1)
Model 080A156 Mounting Base (1)

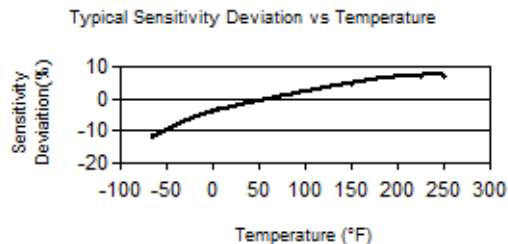

All specifications are at room temperature unless otherwise specified.
In the interest of constant product improvement, we reserve the right to change specifications without notice.
ICP® is a registered trademark of PCB Piezotronics, Inc.

Entered: LK	Engineer: YHK	Sales: MC	Approved: NJF	Spec Number:
Date: 07/30/2019	Date: 07/30/2019	Date: 07/30/2019	Date: 07/30/2019	37457

IMI SENSORS
A PCB PIEZOTRONICS DIV.
3425 Walden Avenue, Depew, NY 14043

Phone: 800-959-4464
Fax: 716-684-3823
E-Mail: imi@pcb.com

PCB Piezotronics Inc. claims proprietary rights in the information disclosed hereon. Neither it nor any reproduction thereof will be disclosed to others without the written consent of PCB Piezotronics Inc.

18551

REVISIONS

REV	DESCRIPTION	DIN
B	ADDED METRIC MOUNTING INFORMATION	43341

METRIC MOUNTING HOLE PREPARATION:

DRILL $\varnothing.199[\varnothing5.05]$ $\nabla.300[7.62]$ MIN $\nabla 1$

TAP M6 X 1-6g $\nabla.200[5.08]$ MIN

ENGLISH MOUNTING HOLE PREPARATION:

DRILL $\varnothing.218[\varnothing5.54]$ $\nabla.300[7.62]$ MIN $\nabla 1$

TAP 1/4-28 UNF-2B $\nabla.200[5.08]$ MIN

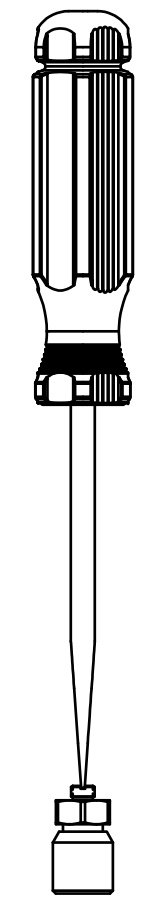
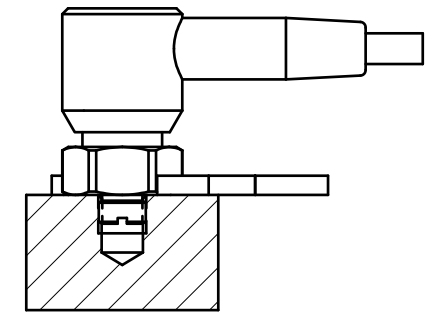
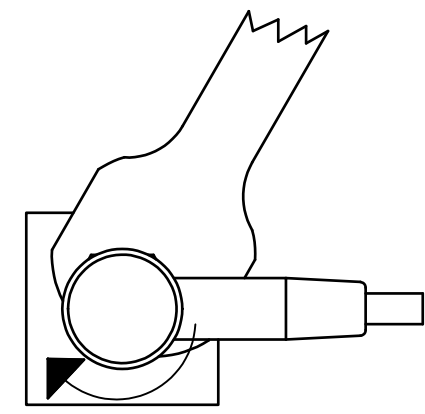
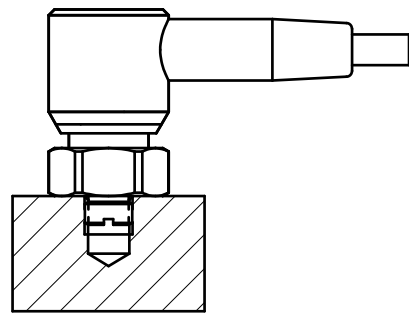
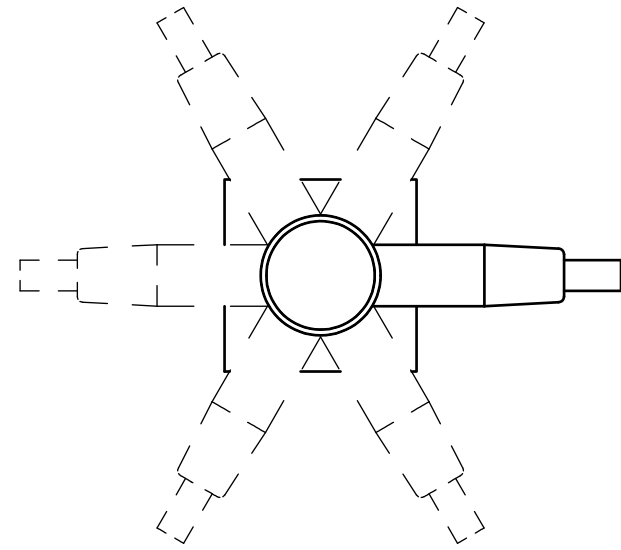
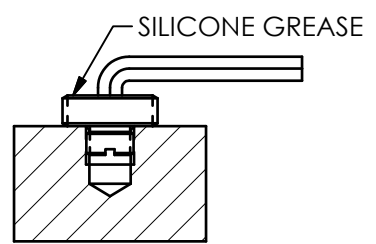
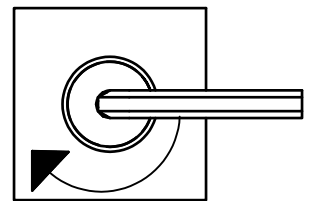
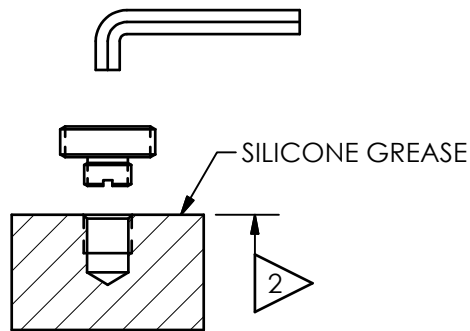
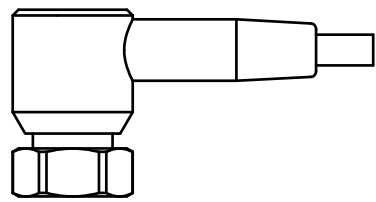

FIG 1: A 1/8" HEX ALLEN KEY IS REQUIRED FOR THE ENGLISH MOUNTING STUD. A 3MM HEX ALLEN KEY IS REQUIRED FOR THE METRIC MOUNTING STUD. APPLY SILICONE GREASE TO ALL MOUNTING SURFACES (SEE ARROWS FIG 1 & 2)

FIG 2: TIGHTEN THE MOUNTING STUD USING THE ALLEN KEY. TORQUE THE MOUNTING STUD TO WITHIN 3 TO 4 FT-LBS. (4.1 TO 5.4 Nm)

FIG 3: THREAD THE SENSOR'S HEX NUT ONTO THE MOUNTING STUD. POSITION THE CABLE OR CONNECTOR TO THE DESIRED LOCATION AND HAND TIGHTEN THE HEX NUT.

FIG 4: TIGHTEN THE HEX NUT USING A TORQUE WRENCH TO WITHIN 2 TO 3 FT-LBS (2.7 TO 4.1 Nm) WHILE HOLDING THE CABLE OR CONNECTOR IN THE DESIRED LOCATION.

FIG 5: IF FOR ANY REASON THE MOUNTING STUD DOES NOT DISENGAGE FROM THE SENSOR, USE A FLAT HEAD SCREW DRIVER TO HOLD THE STUD WHILE TURNING THE HEX NUT COUNTERCLOCKWISE WITH A WRENCH.

3.) FOR BEST RESULTS, PLACE A THIN LAYER OF SILICONE GREASE (DOW CORNING #4 OR EQUIVALENT) ON INTERFACE PRIOR TO MOUNTING.

$\nabla 2$ MOUNTING SURFACE SHOULD BE FLAT TO WITHIN .001 [0.03] TIR WITH A MINIMUM 63 [1.6] FINISH FOR BEST RESULTS.

$\nabla 1$ DRILL PERPENDICULAR TO MOUNTING SURFACE TO WITHIN $\pm 1^\circ$

UNLESS OTHERWISE SPECIFIED TOLERANCES ARE:		DRAWN		CHECKED		ENGINEER	
DIMENSIONS IN INCHES	DIMENSIONS IN MILLIMETERS [IN BRACKETS]	JDM	10/9/14	ECB	10/9/14	DRK	10/9/14
DECIMALS XX ± 0.01 XXX ± 0.005	DECIMALS X ± 0.3 XX ± 0.13	TITLE INSTALLATION DRAWING MODEL 607 SERIES					
ANGLES ± 2 DEGREES	ANGLES ± 2 DEGREES						
FILLETS AND RADII .003 - .005	FILLETS AND RADII 0.07 - 0.13	CODE IDENT. NO. 52681		DWG. NO. 18551		SCALE: FULL SHEET 1 OF 1	

PCB PIEZOTRONICS
3425 WALDEN AVE. DEPEW, NY 14043
(716) 684-0001 E-MAIL: sales@pcb.com

PCB Piezotronics Inc. claims proprietary rights in the information disclosed herein. Neither it nor any reproduction thereof will be disclosed to others without written consent of PCB Piezotronics Inc.

REVISIONS

REV	DESCRIPTION	ECN	DATE	APP'D
NR	RELEASED TO DRAFTING		5/10/07	EB 567

37456

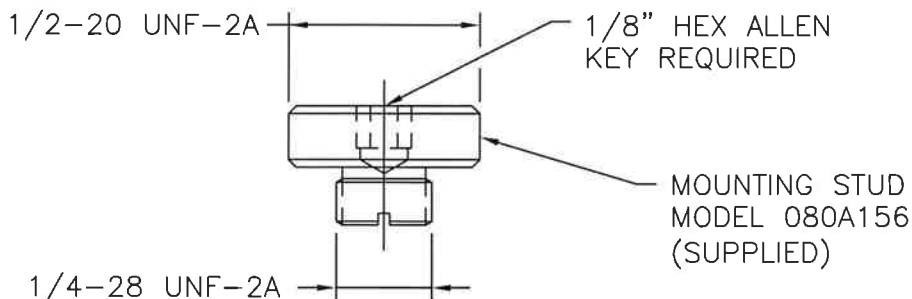
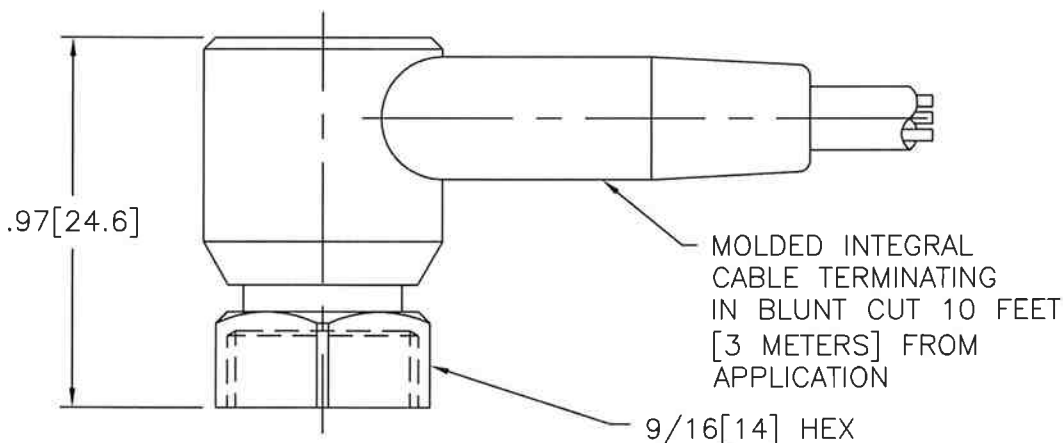
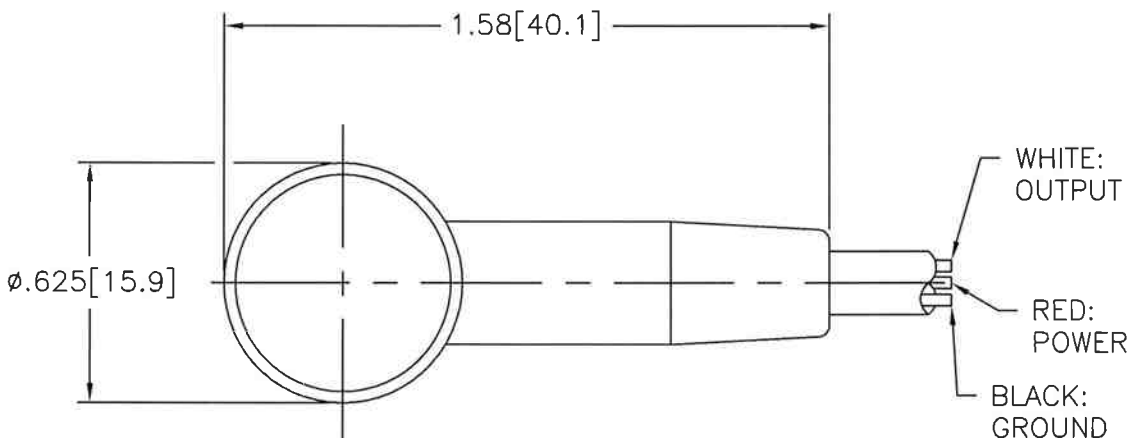

UNLESS SPECIFIED TOLERANCES		DRAWN	MDF	5/14/07	MFG	D. J. 5/11/07	 3425 WALDEN AVE. DEPEW, NY 14043 (716) 684-0001 EMAIL: SALES@PCB.COM	
DIMENSIONS IN INCHES	DIMENSIONS IN MILLIMETERS [IN BRACKETS]	CHK'D	ECB	5/10/07	ENGR	RAB 5/11/07		CODE IDENT. NO. 52681
DECIMALS XX ±.03 XXX ±.010	DECIMALS X ±0.8 XX ±0.25	APP'D	UC	5/11/07	SALES	1/11/07 5/11/07		DWG. NO. 37456
ANGLES ±2 DEGREES	ANGLES ±2 DEGREES	TITLE						SCALE: 2X
FILLETS AND RADII .003 - .005	FILLETS AND RADII [0.07 - 0.13]	OUTLINE DRAWING MODEL 607M83 ACCELEROMETER					SHEET 1 OF 1	
DD011 REV. C 01/21/03								